

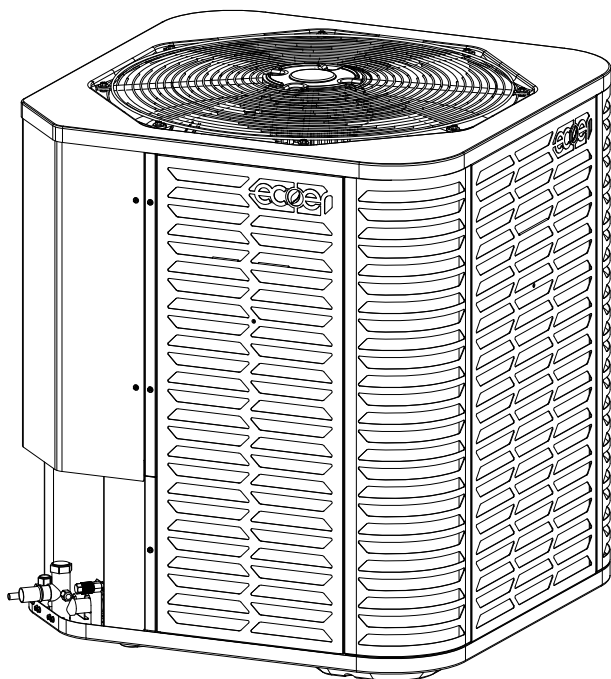

Making your home Green & Smart



Installation Manual

Inverter Ducted Split 2-5 Ton R32 Heat Pump

Contents

1. Safety-----	2
2. Unit Location Considerations-----	10
3. Position the Unit-----	15
4. Refrigerant Line Considerations-----	16
5. Refrigerant Line Routing-----	18
6. Refrigerant Line Connection-----	19
7. System Leak Check-----	21
8. Evacuation and Servicing-----	22
9. Service Valves-----	23
10. Electrical - Low Voltage-----	23
11. Electrical - High Voltage-----	28
12. Start-up-----	29
13. System Charge Adjustment-----	30
14. System Operation-----	35
15. Troubleshooting-----	44
16. Wiring Diagram-----	46

NOTE: Appearance of unit may vary.

Installation must be performed in accordance with the requirements of NEC and CEC by authorized personnel only.



All phases of this installation must comply with National, State and Local Codes.

This document is customer's property and is to remain with this unit. Please return it to customer with service information upon completion of work. These instructions do not cover all variations in systems or provide for every possible contingency to be met in connection with the installation. Should further information be desired or should particular problems arise which are not covered sufficiently for the purchaser's purposes, the matter should be referred to your installing dealer or local distributor.

SAFETY WARNING

Only qualified personnel should install and service the equipment. The installation, starting up, and servicing of heating, ventilating, and air-conditioning equipment can be hazardous and requires specific knowledge and training. Improperly installed, adjusted or altered equipment by an unqualified person could result in death or serious injury. When working on the equipment, observe all pre-cautions in the literature and on the tags, stickers, and labels that are attached to the equipment.

1. Safety

Read the following safety instructions before installing the unit or doing servicing work.

NOTE: R32 refrigerant is a blend and should only be added to the system in liquid state.

 **WARNING** may cause personal death or serious injury.

 **CAUTION** may lead to injury or structural damage under some conditions.



WARNING

HAZARDOUS VOLTAGE

Failure to follow this warning could result in property damage, severe personal injury, or death. Disconnect all electric power, including remote disconnections before servicing. Follow proper lockout/tagout procedures to ensure the power cannot be inadvertently energized.

REFRIGERANT OIL

Any attempt to repair central air conditioner and heat pump products may result in property damage, severe personal injury, or death.

Use only R32 approved service equipment. All R32 systems with variable speed compressors use variable speed compressor oil that readily absorbs moisture from the atmosphere. To limit this "hygroscopic" action, the system should remain sealed whenever possible. If a system has been open to the atmosphere for more than 4 hours, the compressor oil must be replaced. Never break a vacuum with air and always change the driers when opening the system for component replacement.

SERVICE VALVES

Failure to follow this warning will result in abrupt release of system charge and may result in personal injury and/or property damage.

Extreme caution should be exercised when opening the liquid service valve. Turn valve stem counterclockwise only until the stem contacts the rolled edge. No torque is required.

BRAZING REQUIRED

Failure to inspect refrigerant lines or use proper service tools may result in equipment damage or personal injury. If using existing refrigerant lines, make sure that all joints are brazed, not soldered.

HIGH CURRENT LEAKAGE

Failure to follow this warning could result in property damage, severe personal injury, or death. **Grounding is essential before connecting electrical supply.**

SERVICING/RISK OF FIRE

Flammable refrigerant used. Any person who is involved with working on or breaking into a refrigerant circuit should hold a current valid certificate from an industry-accredited assessment authority, which authorises their competence to handle refrigerants safely in accordance with an industry recognised assessment specification.

VENTILATION

Ensure that the area is in the open or that it is adequately ventilated before breaking into the system or conducting any hot work.

CHECKING FOR PRESENCE OF REFRIGERANT

The area shall be checked with an appropriate refrigerant detector prior to and during work, to ensure the technician is aware of potentially toxic or flammable atmospheres. Ensure that the leak detection equipment being used is suitable for use with all applicable refrigerants, i. e. non-sparking, adequately sealed or intrinsically safe.



WARNING

INSTALLATION

Any person who is involved with working on or breaking into a refrigerant circuit should hold a current valid certificate from an industry-accredited assessment authority, which authorises their competence to handle refrigerants safely in accordance with an industry recognised assessment specification.

Maintenance and repair requiring the assistance of other skilled personnel shall be carried out under the supervision of the person competent in the use of flammable refrigerants.

1. That the installation of pipe-work shall be kept to a minimum.
2. That pipe-work shall be protected from physical damage.
3. Where refrigerant pipes shall be compliance with national gas regulations.
4. That mechanical connections shall be accessible for maintenance purposes.
5. Be more careful that foreign matter(oil, water,etc) does not enter the piping. Also, when storing the piping, securely seal the opening by pinching, taping, etc.
6. All working procedure that affects safety means shall only be carried by competent persons.
7. Appliance shall be stored in a well ventilated area where the room size corresponds to the room area as specific for operation.
8. Joints shall be tested with detection equipment with a capability of 5 g/year of refrigerant or better, with the equipment in standstill and under operation or under a pressure of at least these standstill or operation conditions after installation. Detachable joints shall NOT be used in the indoor side of the unit (brazed, welded joint could be used).
9. In cases that require mechanical ventilation, ventilation openings shall be kept clear of obstruction.

THE REQUIREMENTS FOR INSTALLATION SPACE OF APPLIANCE AND/OR VENTILATION REQUIREMENTS

1. The requirements for installation space of appliance and/or ventilation requirements are determined according to the mass charge amount(M) used in the appliance,the installation location,the type of ventilation of the location or of the appliance.
2. Piping material, pipe routing, and installation shall include protection from physical damage in operation and service, and be in compliance with national and local codes and standards, such as ASHRAE 15. IAPMO Uniform Mechanical Code, ICC International Mechanical Code, or CSA. B52. All field joints shall be accessible for inspection prior to being covered or enclosed.
3. That protection devices, piping, and fittings shall be protected as far as possible against adverse environmental effects, for example. the danger of water collecting and freezing in relief pipes or the accumulation of dirt and debris.
4. That piping in refrigeration systems shall be so designed and installed to minimize the likelihood of hydraulic shock damac.na the system.
5. That steel pipes and components shall be protected against corrosion with a rustproof coating before applying any insulation.
6. That precautions shall be taken to avoid excessive vibration or pulsation.
7. The minimum floor area of the room shall be mentioned in the form of a table or a single figure without reference to a formula.
8. After completion of field piping for split systems, the field pipework shall be pressure tested with an inert gas and then vacuum tested prior to refrigerant charging, according to the following requirements.
9. Field-made refrigerant joints indoors shall be tightness tested according to the following requirements: The test method shall have a sensitivity of 5 grams per year of refrigerant or better under a pressure of at least 0,25 times the maximum allowable pressure. No leak shall be detected.



WARNING

QUALIFICATION OF WORKERS

Any maintenance, service and repair operations must be required qualification of the working personnel. Every working procedure that affects safety shall only be carried out by competent persons that joined the training and achieved competence should be documented by a certificate. The training of these procedures is carried out by national training organizations or manufacturers that are accredited to teach the relevant national competency standards that may be set in legislation. All training shall follow the ANNEX HH requirements of UL 60335-2-40 4th Edition.

Examples for such working procedures are:

- breaking into the refrigerating circuit;
- opening of sealed components;
- opening of ventilated enclosures.

In addition, this appliance is not to be used by persons (including children) with reduced physical, sensory or mental capabilities, or lack of experience and knowledge, unless they have been given supervision or instruction concerning use of the appliance by a person responsible for their safety. Children should be supervised to ensure they do not play with the appliance.

WORK PROCEDURE

Works shall be undertaken under a controlled procedure so as to minimise the risk of a flammable gas or vapour being present while the work is being performed.

PRESENCE OF FIRE EXTINGUISHER

If any hot work is to be conducted on the refrigerating equipment or any associated parts, the appropriate fire extinguishing equipment shall be available to hand. Have a dry powder or CO₂ fire extinguisher adjacent to the charging area.

NO IGNITION SOURCES

No person carrying out work in relation to a refrigerating system which involves exposing any pipe work shall use any sources of ignition in such a manner that it may lead to the risk of fire or explosion. All possible ignition sources, including cigarette smoking, should be kept sufficiently far away from the site of installation, repairing, removing and disposal, during which refrigerant can possibly be released to the surrounding space. Prior to work taking place, the area around the equipment is to be surveyed to make sure that there are no flammable hazards or ignition risks. "No Smoking" signs shall be displayed.

CHECKS TO THE REFRIGERATION EQUIPMENT

Where electrical components are being changed, they shall be fit for the purpose and to the correct specification. At all times the manufacturer's maintenance and service guidelines shall be followed. If in doubt, consult the manufacturer's technical department for assistance. The following checks shall be applied to installations using FLAMMABLE REFRIGERANTS as applicable:

1. The actual refrigerant charge is in accordance with the room size within which the refrigerant containing parts are installed.
2. The ventilation machinery and outlets are operating adequately and are not obstructed.
3. If an indirect refrigerating circuit is being used, the secondary circuit shall be checked for the presence of refrigerant.
4. Markings on the equipment should be visible and legible. Markings and signs that are illegible shall be corrected.
5. Refrigerating pipe or components are installed in a position where they are unlikely to be exposed to any substance which may corrode refrigerant containing components, unless the components are constructed of materials which are inherently resistant to being corroded or are suitably protected against being so corroded.



WARNING

CHECKS TO ELECTRICAL DEVICES

For systems containing refrigerant, all repair and maintenance to electrical components shall include initial safety checks and component inspection procedures such as that capacitors are discharged in a safe manner to avoid possibility of sparking, that no live electrical components and wiring are exposed while charging, recovering, or purging the system, and that there is continuity of earth bonding. If a fault exists that could compromise safety, then no electrical supply shall be connected to the circuit until it is satisfactorily dealt with. If the fault cannot be corrected immediately but it is necessary to continue operation, an adequate temporary solution shall be used that is reported to the owner of the equipment, so all parties are advised.

NOTE – Sealed electrical components shall be replaced, not repaired.

NOTE – Intrinsically safe components must be replaced, not repaired.

NOTE – All maintenance staff and others working in the local area shall be instructed on the nature of work being carried out with work in confined spaces being avoided.

DETECTION OF FLAMMABLE REFRIGERANTS

Under no circumstances shall potential sources of ignition be used in the searching for or detection of refrigerant leaks. A halide torch (or any other detector using a naked flame) shall not be used. The following leak detection methods are deemed acceptable for all refrigerant systems. Electronic leak detectors may be used to detect refrigerant leaks but, in the case of flammable refrigerants, the sensitivity may not be adequate, or may need re-calibration. (Detection equipment shall be calibrated in a refrigerant-free area.) Ensure that the detector is not a potential source of ignition and is suitable for the refrigerant used. Leak detection equipment shall be set at a percentage of the LFL of the refrigerant and shall be calibrated to the refrigerant employed, and that 12.5 % refrigerant is confirmed. Leak detection fluids are also suitable for use with most refrigerants but the use of detergents containing chlorine shall be avoided as the chlorine may react with the refrigerant and corrode the copper pipe-work. If a leak is suspected, all naked flames shall be removed/extinguished. If a leakage of refrigerant is found which requires brazing, all of the refrigerant shall be recovered from the system, or isolated (by means of shut off valves) in a part of the system remote from the leak.

REMOVAL AND EVACUATION

When breaking into the refrigerant circuit to make repairs or for any other purpose – conventional procedures shall be used. However, for flammable refrigerants it is important that best practice be followed and, since flammability is a consideration, procedures such as safely remove refrigerant following local and national regulations, purging the circuit with inert gas, evacuating (optional for A2L), purging with inert gas (optional for A2L), or opening the circuit by cutting or brazing be adhered to. The refrigerant charge shall be recovered into the correct recovery cylinders if venting is not allowed by local and national codes. For appliances containing flammable refrigerants, the system shall be purged with oxygen-free nitrogen to render the appliance safe for flammable refrigerants. This process might need to be repeated several times. Compressed air or oxygen shall not be used for purging refrigerant systems. For appliances containing flammable refrigerants, refrigerants purging shall be achieved by breaking the vacuum in the system with oxygen-free nitrogen and continuing to fill until the working pressure is achieved, then venting to atmosphere, and finally pulling down to a vacuum (optional for A2L). This process shall be repeated until no refrigerant is within the system (optional for A2L). When the final oxygen-free nitrogen charge is used, the system shall be vented down to atmospheric pressure to be able to perform the required work. Ensure that the outlet for the vacuum pump is not close to any potential ignition sources and working area is well ventilated.



WARNING

CABLING

Check that cabling will not be subject to wear, corrosion, excessive pressure, vibration, sharp edges or any other adverse environmental effects. The check shall also take into account the effects of aging or continual vibration from sources such as compressors or fans.

CHARGING PROCEDURES

In addition to conventional charging procedures; the following requirements shall be followed:

- Works shall be undertaken with appropriate tools only (In case of uncertainty, please consult the manufacturer of the tools for use with flammable refrigerants) .
- Ensure that contamination of different refrigerants does not occur when using charging equipment.
- Hoses or lines shall be as short as possible to minimize the amount of refrigerant contained in them.
- Cylinders shall be kept upright.
- Ensure that the refrigeration system is earthed prior to charging the system with refrigerant.
- Label the system when charging is complete (if not already).
- Extreme care shall be taken not to overfill the refrigeration system.
- Prior to recharging the system it shall be pressure tested with oxygen free nitrogen (OFN), The system shall be leak tested on completion of charging but prior to commissioning.
- A follow up leak test shall be carried out prior to leaving the site.

DECOMMISSIONING

Before carrying out this procedure, it is essential that the technician is completely familiar with the equipment and all its detail. It is recommended good practice that all refrigerants are recovered safely. Prior to the task being carried out, an oil and refrigerant sample shall be taken in case analysis is required prior to re-use of recovered refrigerant. It is essential that electrical power is available before the task is commenced.

- a. Become familiar with the equipment and its operation.
- b. Isolate system electrically.
- c. Before attempting the procedure ensure that:
 - mechanical handling equipment is available, if required, for handling refrigerant cylinders;
 - all personal protective equipment is available and being used correctly;
 - the recovery process is supervised at all times by a competent person;
 - recovery equipment and cylinders conform to the appropriate standards.
- d. Pump down refrigerant system, if possible.
- e. If a vacuum is not possible, make a manifold so that refrigerant can be removed from various parts of the system.
- f. Make sure that cylinder is situated on the scales before recovery takes place.
- g. Start the recovery machine and operate in accordance with instructions.
- h. Do not overfill cylinders (no more than 80 % volume liquid charge).
- i. Do not exceed the maximum working pressure of the cylinder, even temporarily.
- j. When the cylinders have been filled correctly and the process completed, make sure that the cylinders and the equipment are removed from site promptly and all isolation valves on the equipment are closed off.
- k. Recovered refrigerant shall not be charged into another refrigeration system unless it has been cleaned and checked.

LABELLING

Equipment shall be labelled stating that it has been de-commissioned and emptied of refrigerant. The label shall be dated and signed. For appliances containing FLAMMABLE REFRIGERANTS; ensure that there are labels on the equipment stating the equipment contains FLAMMABLE REFRIGERANT.



WARNING

RECOVERY

When removing refrigerant from a system, either for servicing or decommissioning, it is recommended good practice that all refrigerants are removed safely.

When transferring refrigerant into cylinders, ensure that only appropriate refrigerant recovery cylinders are employed. Ensure that the correct number of cylinders for holding the total system charge is available. All cylinders to be used are designated for the recovered refrigerant and labelled for that refrigerant (i. e. special cylinders for the recovery of refrigerant). Cylinders shall be complete with pressure-relief valve and associated shut-off valves in good working order. Empty recovery cylinders are evacuated and, if possible cooled before recovery occurs.

The recovery equipment shall be in good working order with a set of instructions concerning the equipment that is at hand and shall be suitable for the recovery of the flammable refrigerant. If in doubt, the manufacturer should be consulted. In addition, a set of calibrated weighing scales shall be available and in good working order. Hoses shall be complete with leak-free disconnect couplings and in good condition.

The recovered refrigerant shall be processed according to local legislation in the correct recovery cylinder, and the relevant waste transfer note arranged. Do not mix refrigerants in recovery units and especially not in cylinders.

If compressors or compressor oils are to be removed, ensure that they have been evacuated to an acceptable level to make certain that flammable refrigerant does not remain within the lubricant. The compressor body shall not be heated by an open flame or other ignition sources to accelerate this process. When oil is drained from a system, it shall be carried out safely.

UNVENTILATED AREAS

For appliances containing more than any refrigerating circuit, the manual shall include a statement advising that an unventilated area where the appliance using FLAMMABLE REFRIGERANTS is installed shall be so constructed that should any refrigerant leak, it will not stagnate so as to create a fire or explosion hazard. This shall include:

1. A warning that if appliances with A2L REFRIGERANTS connected via an air duct system to one or more rooms are installed in a room with an area less than $>A_{min}$ as determined in Clause GG.2, that room shall be without continuously operating open flames (for example an operating gas appliance) or other POTENTIAL IGNITION SOURCES (for example an operating electric heater, hot surfaces). A flame-producing device may be installed in the same space if the device is provided with an effective flame arrest.

2. For appliances using A2L REFRIGERANTS connected via an air duct system to one or more rooms, a warning with the substance of the following: "Auxiliary devices which may be a POTENTIAL IGNITION SOURCE shall not be installed in the duct work. Examples of such POTENTIAL IGNITION SOURCES are hot surfaces with a temperature exceeding X °C and electric switching devices".

NOTE X is the maximum allowable surface temperature as defined in 22.117.

The manufacturer should specify other potential continuously operating sources known to cause ignition of the refrigerant used.

The appliance shall be stored so as to prevent mechanical damage from occurring.

3. For appliances using A2L refrigerants connected via an air duct system to one or more rooms, a warning that only auxiliary devices approved by the appliance manufacturer or declared suitable with the refrigerant shall be installed in connecting ductwork. The manufacturer shall list in the instructions all approved auxiliary devices by manufacturer and model number for use with the specific appliance, if those devices have a potential to become an ignition source.



WARNING

4. A warning that if appliances connected via an air duct system to one or more rooms with A2L REFRIGERANTS are installed in a room with an area less than 4 minutes as determined in Clause GG.2. or installed in a room with an EFFECTIVE DISPERSAL VOLUME VED less than the minimum as determined by Clause 101.DVN.8, that room shall be without continuously operating open flames (e.g. an operating gas appliance) or other POTENTIAL IGNITION SOURCES (for e.g. an operating electric heater hot surfaces). A flame-producing device may be installed in the same space if the device is provided with an effective flame arrest.

5. For REFRIGERANT DETECTION SYSTEMS, the function and operation and required servicing measures.

6. For LIMITED LIFE REFRIGERANT SENSORS Used in REFRIGERANT DETECTION SYSTEMS, the specified end-of-life and replacement instructions.

7. REFRIGERANT SENSORS for REFRIGERANT DETECTION SYSTEMS Shall Only be replaced with sensors specified by the appliance manufacture; and instructions to verify actuation of mitigation actions per Annex GG or Annex 101.DVN as applicable.

For appliances using FLAMMABLE REFRIGERANTS with safety features that depend upon the proper function of a leak detection system used for leak mitigation, the instructions and unit markings shall contain the substance of the following:

"LEAK DETECTION SYSTEM installed. Unit must be powered except for service." If any remote located REFRIGERANT SENSOR is employed to detect leaked refrigerant, such a remote located REFRIGERANT SENSOR shall also apply to this marking or be accompanied by such instructions.

TRANSPORTATION, MARKING AND STORAGE

a. General

The following information is provided for units that employ FLAMMABLE REFRIGERANTS.

b. Transport of equipment containing flammable refrigerants

Attention is drawn to the fact that additional transportation regulations may exist with respect to equipment containing flammable gas. The maximum number of pieces of equipment or the configuration of the equipment permitted to be transported together will be determined by the applicable transport regulations.

c. Marking of equipment using signs

Signs for similar appliances used in a work area are generally addressed by local regulations and give the minimum requirements for the provision of safety and/or health signs for a work location.

All required signs are to be maintained and employers should ensure that employees receive suitable and sufficient instruction and training on the meaning of appropriate safety signs and the actions that need to be taken in connection with these signs:

The effectiveness of signs should not be diminished by too many signs being placed together.

Any pictograms used should be as simple as possible and contain only essential details.

d. Disposal of equipment using flammable refrigerants

See national regulations.

e. Storage of equipment/appliances

The storage of the appliance should be in accordance with the applicable regulations or instructions, whichever is more stringent.

f. Storage of packed (unsold) equipment

Storage package protection should be constructed in such a way that mechanical damage to the equipment inside the package will not cause a leak of the REFRIGERANT CHARGE.

The maximum number of pieces of equipment permitted to be stored together will be determined by local regulations.



CAUTION

AUTHORIZED PERSONNEL ONLY

This information is intended for use by individuals possessing adequate backgrounds of electrical and mechanical experience. Any attempt to repair central air conditioner or heat pump products may result in personal injury and/or property damage.

INDOOR UNIT REQUIREMENT

It is recommended to equip indoor units with **adjustable TXV/EEV for R32 heat pump**.
The model of TXV/EEV should be suitable for the system capacity and should be with internal check valves for heat pump, which can be verified to work properly by checking superheat in cooling.

No micro channel coil shall be used for heat pump.

Micro channel coils are suitable for cooling only system.

HOT SURFACE

May cause minor to severe burns

Failure to follow this caution could result in property damage or personal injury.

Do not touch top of compressor.





GROUNDING REQUIRED

Failure to inspect or use proper service tools may result in equipment damage or personal injury. Reconnect all grounding devices. All parts of this product that are capable of conducting electrical current are grounded. If grounding wires, screws, straps, clips, nuts, or washers used to complete a path to ground are removed for service, it must be returned to their original position and properly fastened.

CONTAINS REFRIGERANT

Failure to follow proper procedures can result in personal illness or injury or severe equipment damage. System contains oil and refrigerant under high pressure. Recover refrigerant to relieve pressure before opening the system.

Explanation of symbols displayed on the indoor unit or outdoor unit

	WARNING	This symbol shows that this appliance used a flammable refrigerant. If the refrigerant is leaked and exposed to an external ignition source, there is a risk of fire.
	CAUTION	This symbol shows that the operation manual should be read carefully.
	CAUTION	This symbol shows that information is available such as the operating manual or installation manual.
	CAUTION	This symbol shows that a service personnel should be handling this equipment with reference to the installation manual.

2. Unit Location Considerations

2.1 Inspect Units

Units are packaged for shipment to avoid damage during normal transit and handling. It is the receiving party's responsibility to inspect the equipment upon arrival. Any obvious damage to the carton box should be reported on the bill of lading and a claim should be filed with the transportation company, and the factory should be noticed.

All units should be stored in the factory shipping carton with internal packaging in a dry place until installation. Carefully remove the packaging and inspect for hidden damage. Any hidden damage should be recorded and the factory should be notified. The gauge port can be used to check the refrigerant charge has been retained during shipment.

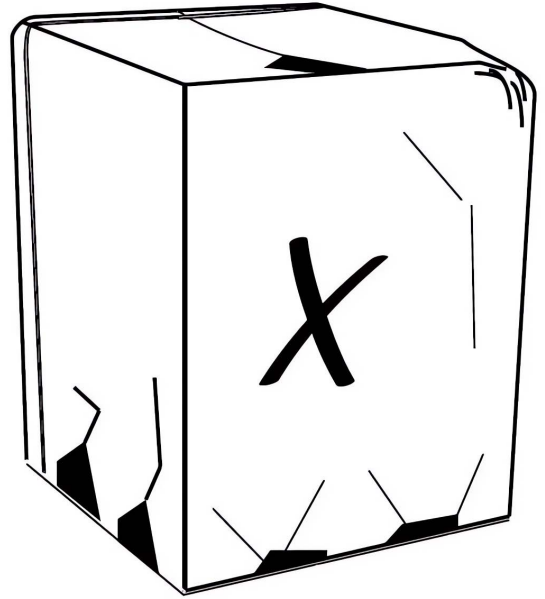

Fig 2-1 Check damage

2.2 Unit Dimensions

Two models sharing the same chassis are suit for most residential air conditioner and heat pump applications.

Table 2-1 Condensing unit dimensions

Unit Dimensions	
Model	H x W x D (Inches)
2436	24-1/4 x 29-1/8 x 29-1/8
4860	32-1/2 x 29-1/8 x 29-1/8

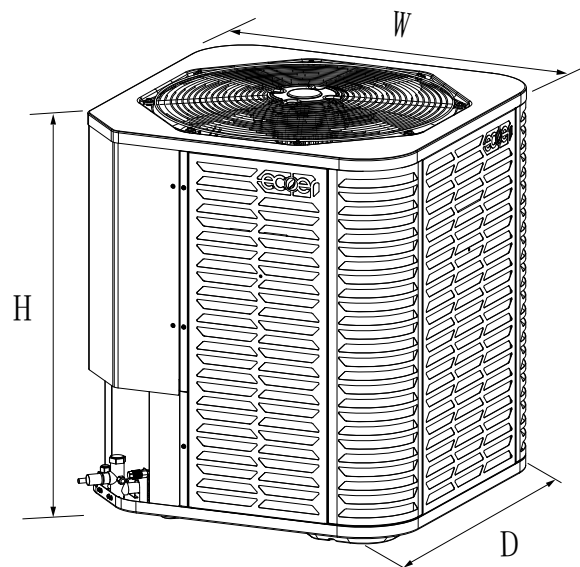

Fig 2-2 External dimensions

2.3 Location Restrictions

WARNING

Flammable refrigerant!

Appliance shall be installed, operated in a room that meets special requirements and has an area limit as shown in Section 2.4

WARNING

Flammable refrigerant!

The outdoor unit shall be located in a well-ventilated location other than the occupied space, such as in the open air. For installation of the indoor unit, refer to the corresponding installation and operation manual. If an indoor unit is installed in an unventilated area, the area shall be so constructed that should any refrigerant leak, it will not stagnate so as to create a fire or explosion hazard.

Exposure to a corrosive environment may shorten the life of the equipment, corrode metal parts, and/or negatively affect unit performance. Corrosive elements include, but are not limited to: sodium chloride, sodium hydroxide, sodium sulfate, and other compounds commonly found in ocean water, sulfur, chlorine, fluorine, fertilizers, and various chemical contaminants from industry/manufacturing plants. If installed in areas which may be exposed to corrosive environments, special attention should be given to the equipment placement and maintenance.

- Lawn sprinklers/waste water should not spray directly on the unit cabinet for prolonged periods.
- In coastal areas: The outdoor unit should be installed at a location that is at least 1000 feet away from the coast and on the side of the building that is farthest from the coast.

Installation Clearance Requirement

Ensure the top discharge area is unrestricted for at least **60 inches** above the unit.

Do not locate condensing unit near bedrooms because normal operational sounds may be annoying. Position unit to allow adequate space for unobstructed airflow, wiring, refrigerant lines, and serviceability.

Allow a minimum of 12 in. clearance on one side of access panel to a wall and a minimum of 24 in. on the adjacent side of access panel. **Maintain a distance of 24 in. between units.**

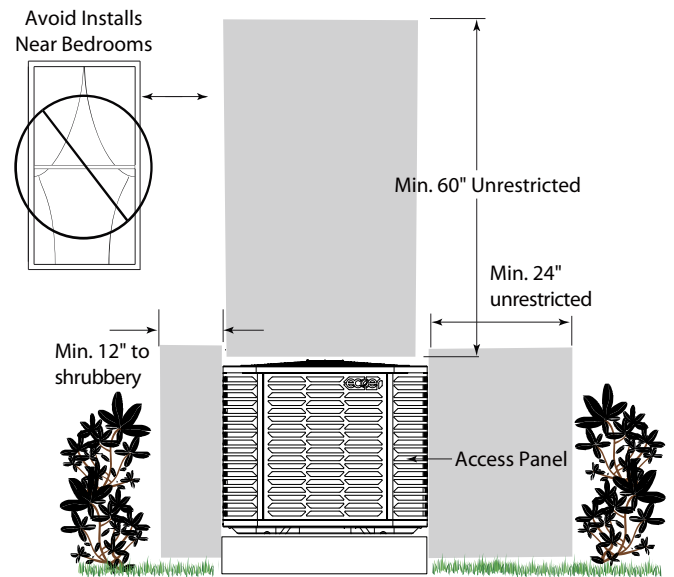

Fig 2-3 Clearance requirement

Position unit so water, snow, or ice from roof or overhang cannot fall directly on unit.

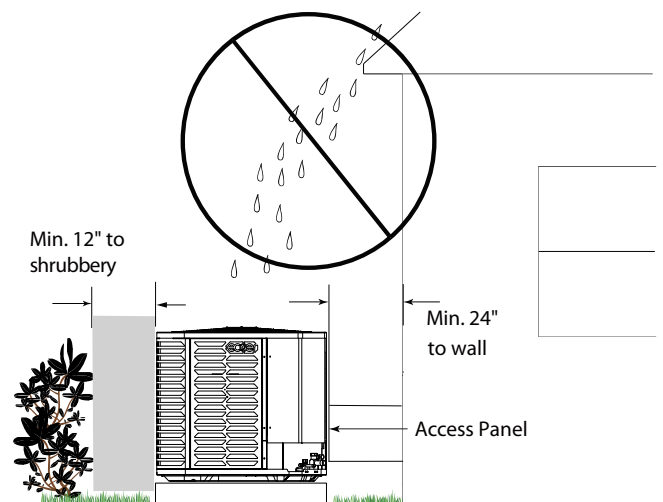

Fig 2-4 Unit location

Cold Climate Considerations

Precautions must be taken for units being installed in areas where snow accumulation and prolonged below-freezing temperatures occur.

Elevate unit per local climate and code requirements.

- Where snowfall is anticipated, raise the unit above the base pad to prevent ice buildup and coil damage. Mount the unit high enough to be above the average accumulated area snowfall.
- If unit must be elevated because of anticipated snowfall, secure unit and elevating stand such that unit and/or stand will not tip over or fall off.

A snow drift barrier should be installed around the unit to prevent a build-up of snow on the unit sides.

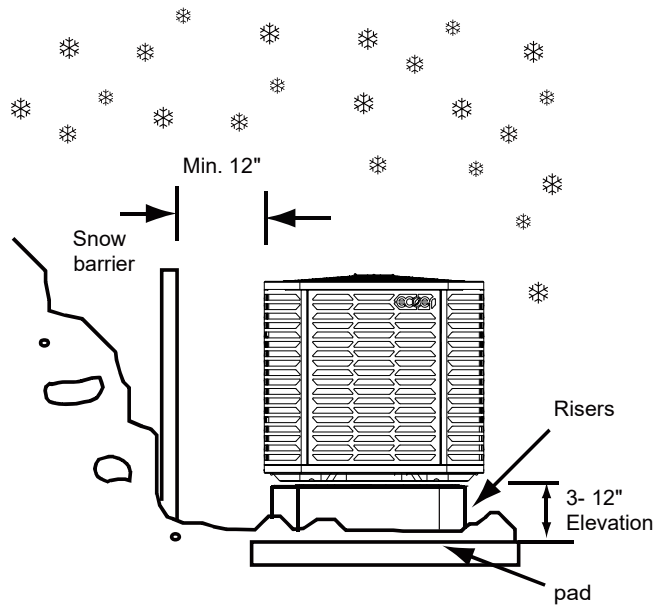

Fig 2-5 Consideration to prevent refreezing

Snow Guard Kit Cautions

No kit shall damage the top panel of condensing unit.

- Main control board (MCB) will be damaged due to the rainwater flow into the control box.
- The condensing coil will be broken resulting in refrigerant leak.

In areas prone to blizzards and freezing rain, it is advisable to install a snow guard for added protection.



Fig 2-6 Snow Guard Kit

2.4 Refrigerant Charge and Room Area Limitations

2.4.1 Opening conditions for connected rooms

The appliances are connected via an air duct system to one or more rooms, the bottom of the air outlet of the air duct in the room should be at a height $\geq 7.3\text{ft}/2.2\text{m}$ from the floor. In UL/CSA 60335-2-40, the R32 refrigerant belongs to mildly flammable refrigerants, which will limit the room area of the system service. Similarly, the total amount of refrigerant in the system should be less than or equal to the maximum allowable refrigerant charge, which depends on the room area serviced by the system.

Note: For minimum room areas at higher installation heights, see instructions (note is optional).
Installation method:

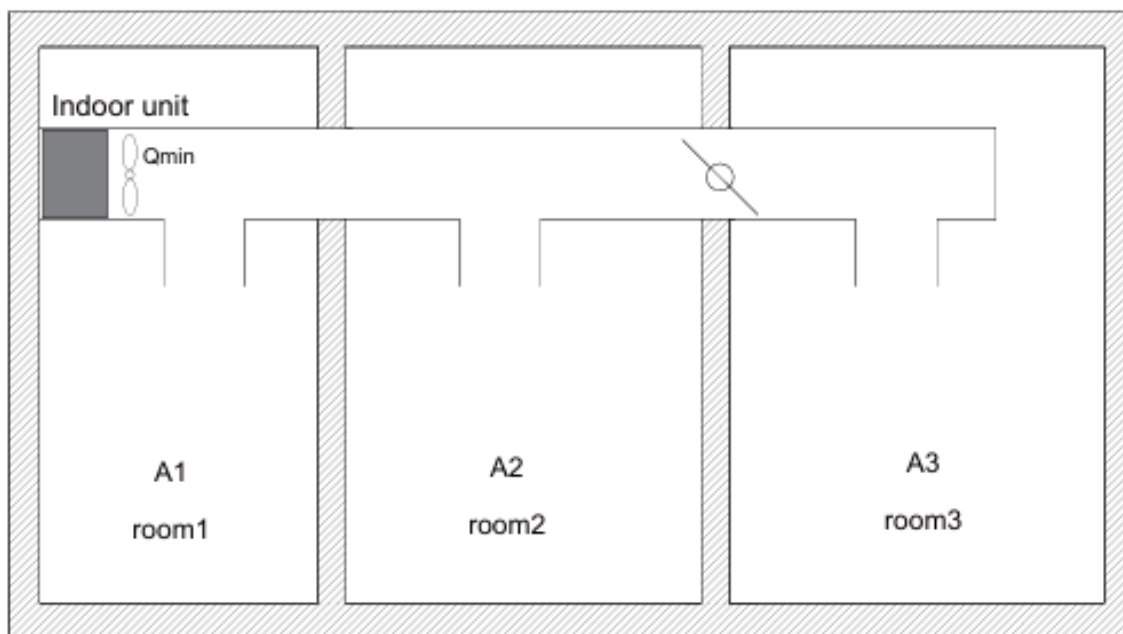

Make sure that the applied room space area T_A is larger than the T_{Amin} .

2.4.2 R32 refrigerant charge amount and minimum room area

Mc [oz/kg]	TA _{min} [ft ² /m ²]	Mc [oz/kg]	TA _{min} [ft ² /m ²]	Mc [oz/kg]	TA _{min} [ft ² /m ²]	Mc [oz/kg]	TA _{min} [ft ² /m ²]
56.5/1.6	51/4.74	134/3.8	126/11.67	211.6/6.0	198/18.43	289.2/8.2	271/25.18
63.5/1.8	60/5.53	141.1/4	132/12.29	218.7/6.2	205/19.04	296.3/8.4	278/25.8
70.5/2	66/6.14	148.1/4.2	139/12.9	225.8/6.4	212/19.66	303.4/8.6	284/26.41
77.6/2.2	73/6.76	155.2/4.4	145/13.51	232.8/6.6	218/20.27	310.4/8.8	291/27.63
84.6/2.4	79/7.37	162.2/4.6	152/14.13	239.9/6.8	225/20.88	317.5/9.0	298/27.64
91.7/2.6	86/7.99	169.3/4.8	159/14.74	246.9/7.0	231/21.5	324.5/9.2	304/28.26
98.8/2.8	93/8.6	176.4/5	165/15.36	254/7.2	238/22.11	331.6/9.4	311/28.87
105.8/3	99/9.21	183.4/5.2	172/15.97	261/7.4	245/22.73	338.6/9.6	317/29.48
112.9/3.2	106/9.83	190.5/5.4	179/16.58	268.1/7.6	251/23.34	345.7/9.8	324/30.10
119.9/3.4	112/10.44	197.5/5.6	185/17.2	275.1/7.8	258/23.96	352.7/10.0	331/30.71
127/3.6	119/11.06	204.6/5.8	192/17.81	282.2/8.0	264/24.57		
Area formula	<p>TA_{min} is the required minimum room area in ft² / m² Mc is the actual refrigerant charge in the system in oz/kg h_{inst} is the height of the bottom of the appliance relative to the floor of the room after installation. WARNING: The minimum room area or minimum room area of conditioned space is based on releasable charge and total system refrigerant charge. Note: TA=A1+A2+A3+...+An (If there is a damper in the duct. When damper is open, the room area TA is the sum of all room area connected by ductwork. If it is closed, TA is the sum of the room areas before the damper.) Note: Calculate Mc by considering the length of pipeline connections,0.6 oz/ft. (Liquid line size 3/8)</p>						

When the unit detects a refrigerant leak, the minimum airflow of the indoor unit is as follows:
 (The output air volume is based on the machine's full load air volume)

Model	24K	36K	48K	60K
Q _{minA} [m ³ /h(SCFM)]	791(466)	791(466)	1136(669)	1136(669)
Q _{min} [m ³ /h(SCFM)]	832(490)	1248(735)	1783(1050)	1953(1150)
Note: Q _{min} refers to the Minimum airflow of the indoor unit , which is not less than Q _{minA} .				

3. Position the Unit

When mounting the unit on a roof, be sure the roof will support the unit's weight obtained from nameplate.

Properly selected isolation is recommended to prevent sound or vibration transmission to the building structure. If elevating a unit on a flat roof, use 4" x 4" or equivalent stringers positioned to distribute unit weight evenly and prevent noise and vibration.

When installing the unit on a support pad, such as a concrete slab, consider the following:

- The pad must be 1~2" larger than the unit on all sides.
- The pad must be separated from any structure.
- The pad must be level.
- The pad must be high enough above grade to allow for drainage.
- The pad location must comply with National, State and Local codes.

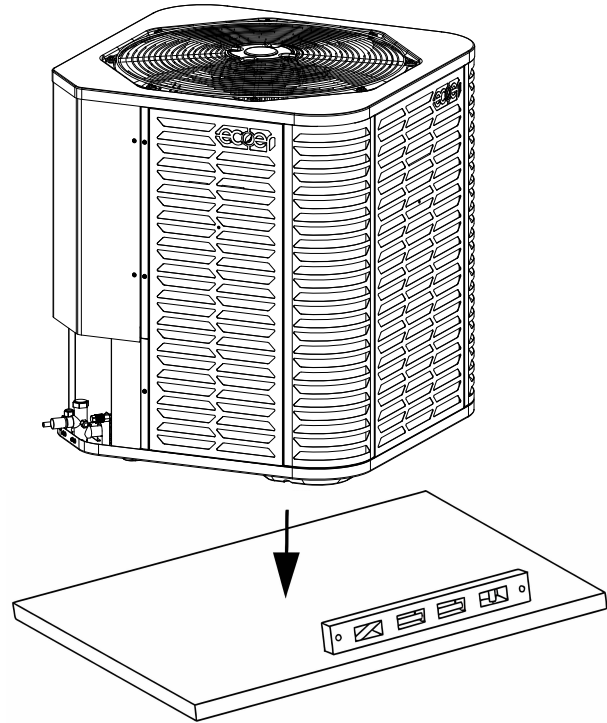

Fig 3-1 Position the unit on pad

IMPORTANT NOTE:

These instructions are intended to provide a method to tie-down unit to cement slab as a securing procedure for high wind areas. Check local codes for tie-down methods and protocols.

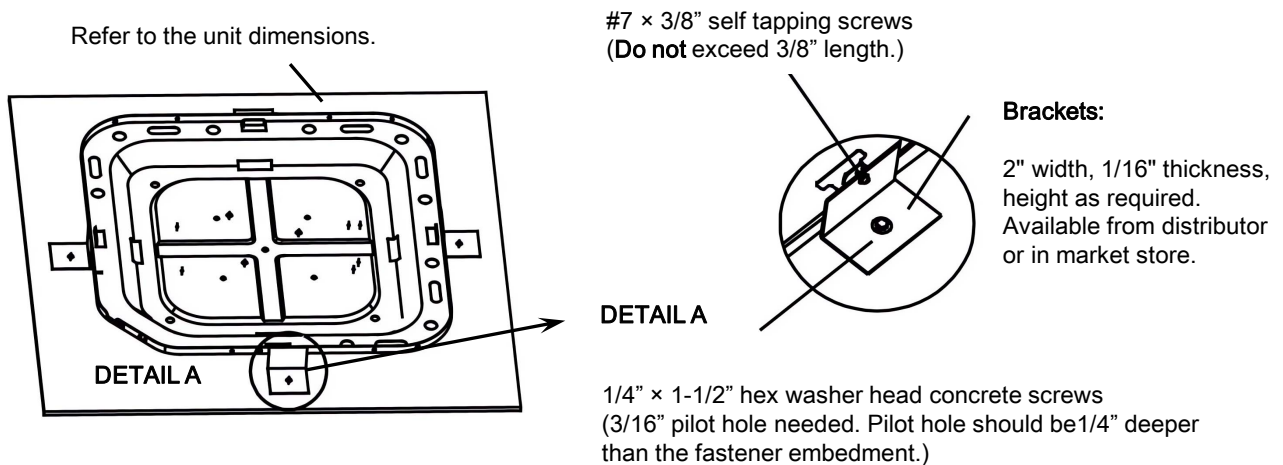

Fig 3-2 Fasten the condensing unit

4. Refrigerant Line Considerations

4.1 Refrigerant Line Limits

Use only the line sizes indicated in table below and determine required line length. If the suction line sets are greater than 50 feet, do not use a larger suction line than recommended.

Table 4-1 Line sizes and maximum length

Model	Liquid Line	Suction Line	Total Equivalent Length (FT)					
			25	50	75	100	125	150
	Dimensions in inches		Maximum Elevation Difference (FT)					
2Ton	3/8 Std.	3/4 Std.	25	50	45	40	30	25
	1/4 Opt.	5/8 Opt.	25	50	40	30	30	25
3Ton	3/8 Std.	3/4 Std.	25	50	50	50	35	25
	1/4 Opt.	5/8 Opt.	25	50	45	40	35	25
4Ton	3/8	7/8 Std.	25	50	50	40	30	25
		3/4 Opt.	25	50	50	40	30	25
5Ton	3/8	7/8 Std.	25	50	50	40	30	25
		3/4 Opt.	25	50	50	40	30	25

Std.: Standard line size; **Opt.:** Optional line size; **N/A:** Application not recommended

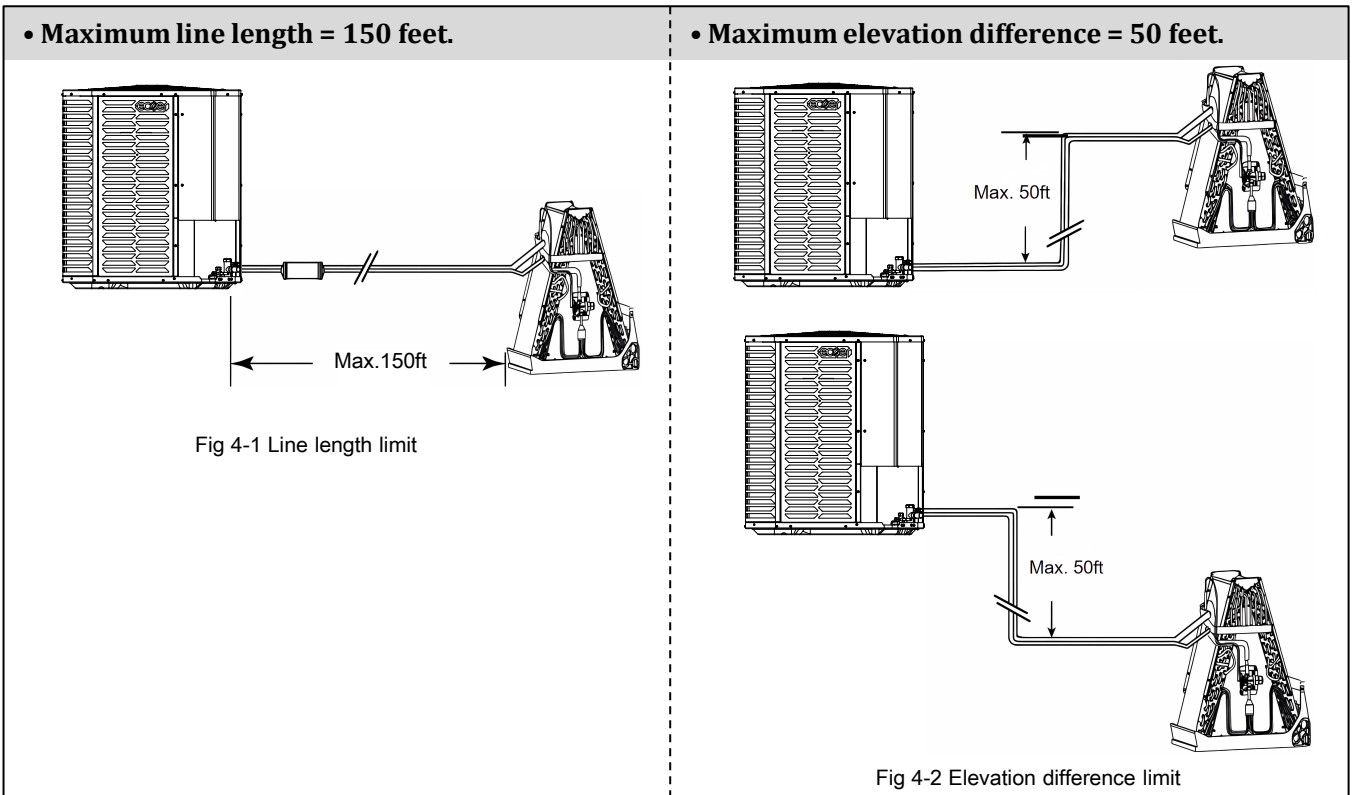

4.2 Refrigerant Line Insulation

The suction line must always be insulated.

DO NOT allow the suction line and liquid line to come in direct (metal to metal) contact.

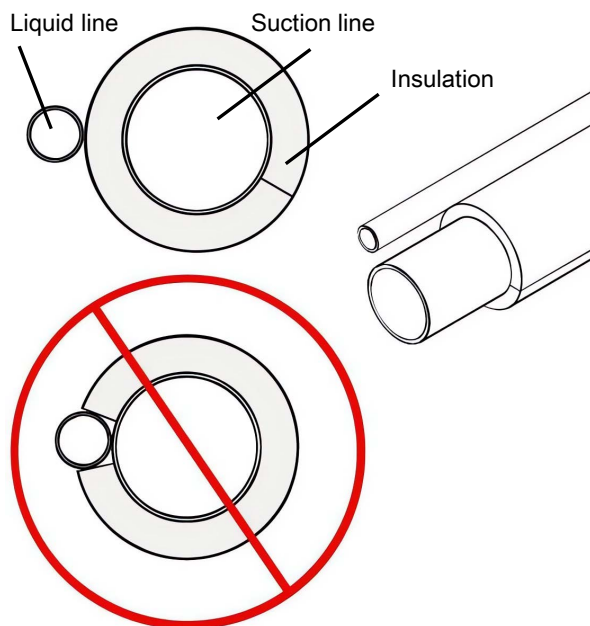

Fig 4-3 Line insulation

4.3 Reuse Existing Refrigerant Lines

⚠ CAUTION

If you using existing refrigerant lines, ensure that all joints are brazed, not soldered.

For retrofit applications where the existing refrigerant lines will be used, the following precautions should be taken:

- Ensure that the refrigerant lines are the correct size according to Table 4-1. It's not recommended to use suction line bigger than standard size, in which will result poor oil return for inverter compressor.
- Ensure that the refrigerant lines are **free of leaks, acid and mineral oil**. When replacing R22 system with a new R32 system, be sure the existing lines can endure R32 pressure which is 50~70% higher than R22 system. Use flush (e.g. R_x11) to remove the old mineral oil, sludge, moisture, acid and other contaminants out of the line set.

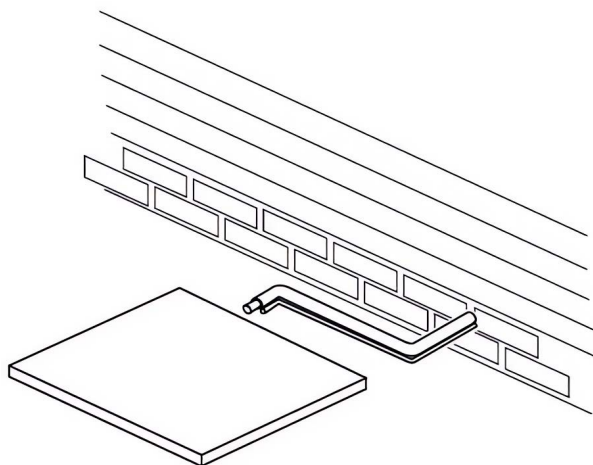

Fig 4-4 Use existing refrigerant lines

IMPORTANT:

It is recommended to equip indoor units with adjustable TXV/EEV for R32 heat pump. The model of TXV/EEV should be suitable for the system capacity and should be with internal check valves for heat pump, which can be verified to work properly by checking superheat in cooling. No micro channel coil shall be used for heat pump. Micro channel coils are suitable for cooling only system.

5. Refrigerant Line Routing

Comply with National, State, and Local Codes when isolating line sets from joists, rafters, walls, or other structural elements. Take precautions to prevent noise within the building structure due to vibration transmission from the refrigerant lines. For Example:

- Use isolation type hangers when the refrigerant lines have to be fastened to floor joists or other framing.
- Isolation hangers should also be used when refrigerant lines traverse stud spaces or enclosed ceilings.
- Where the refrigerant lines pass through a wall or sill, it should be insulated and isolated.
- Isolate the lines from all ductwork.
- Minimize the number of 90° turns.

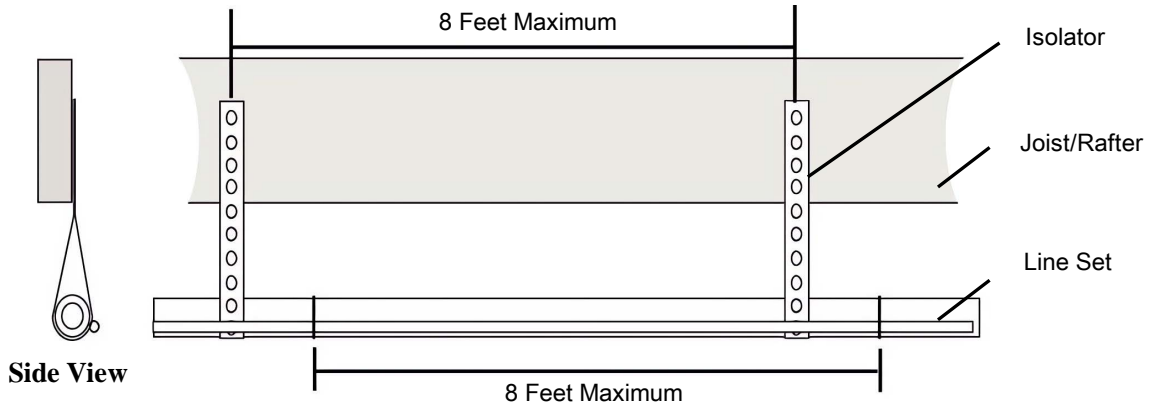

Secure suction line from joists using isolators every 8 ft. Secure liquid line directly to insulated suction line using tape, wire, or other appropriate method every 8 ft.

Fig 5-1 Isolation from Joist/Rafter

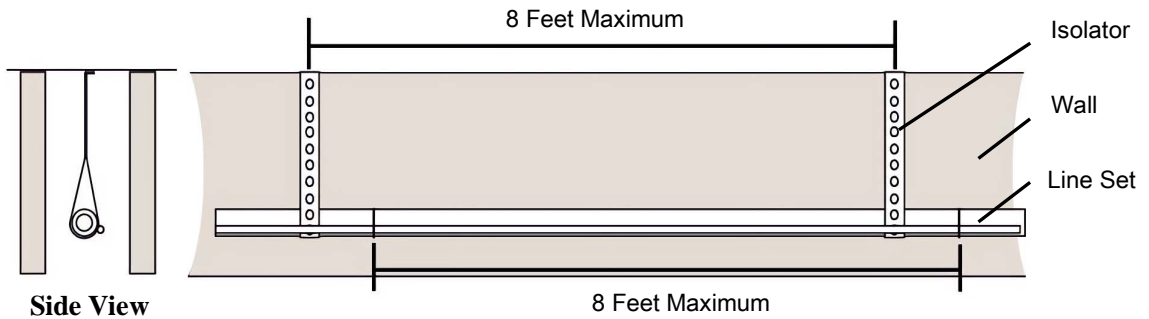

Secure suction line using isolators every 8 ft. Secure liquid line directly to insulated suction line using tape, wire, or other appropriate method every 8 ft.

Fig 5-2 Isolation in wall spaces

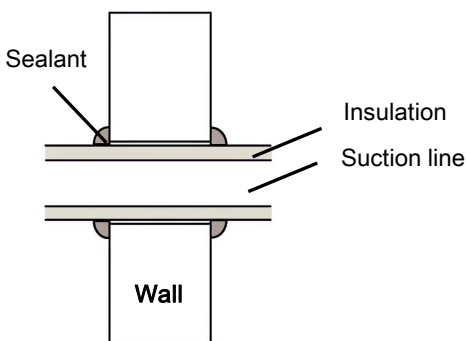

Fig 5-3 Isolation through wall

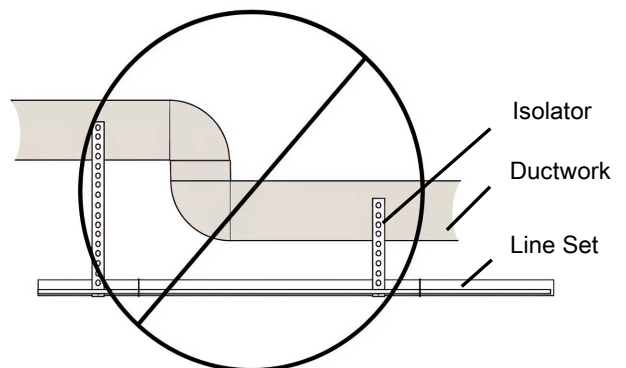

Fig 5-4 DO NOT hang line sets from ductwork

6. Refrigerant Line Connection

6.1 Refrigerant Line Press Fitting Connection

This Press Fitting connection operation is for reference only. Please follow the official instructions provided by Press Fitting Tools for operation.

1. Remove caps or plugs. Use a tool to deburr the line ends. Clean both internal and external surfaces of the tubing using an emery cloth.
2. Remove the pressure tap cap from both service valves.
3. Use a rotary tube cutter to cut off the copper tube to length, ensure that the tube is cut square.
4. Using a reamer or deburring tool, remove all burrs from the cut section of the pipe.
5. Use a pencil type deburrer on internal tube edges.
6. Thoroughly clean the tube end using a general purpose hand pad or sand cloth in a rotating motion.
7. Install a bidirectional filter drier (NO active alumina allowed) in liquid line to protect the heat pump. Insert the tube fully into the fitting. Ensure tube is fully inserted prior to pressing.
8. Align jaws squarely on the fitting, complete the joint with the approved tool. Press once only.
9. Evacuate the refrigerant lines.
10. After completing the evacuation, install the pressure tap caps back using a torque of 1.5-2N•m.

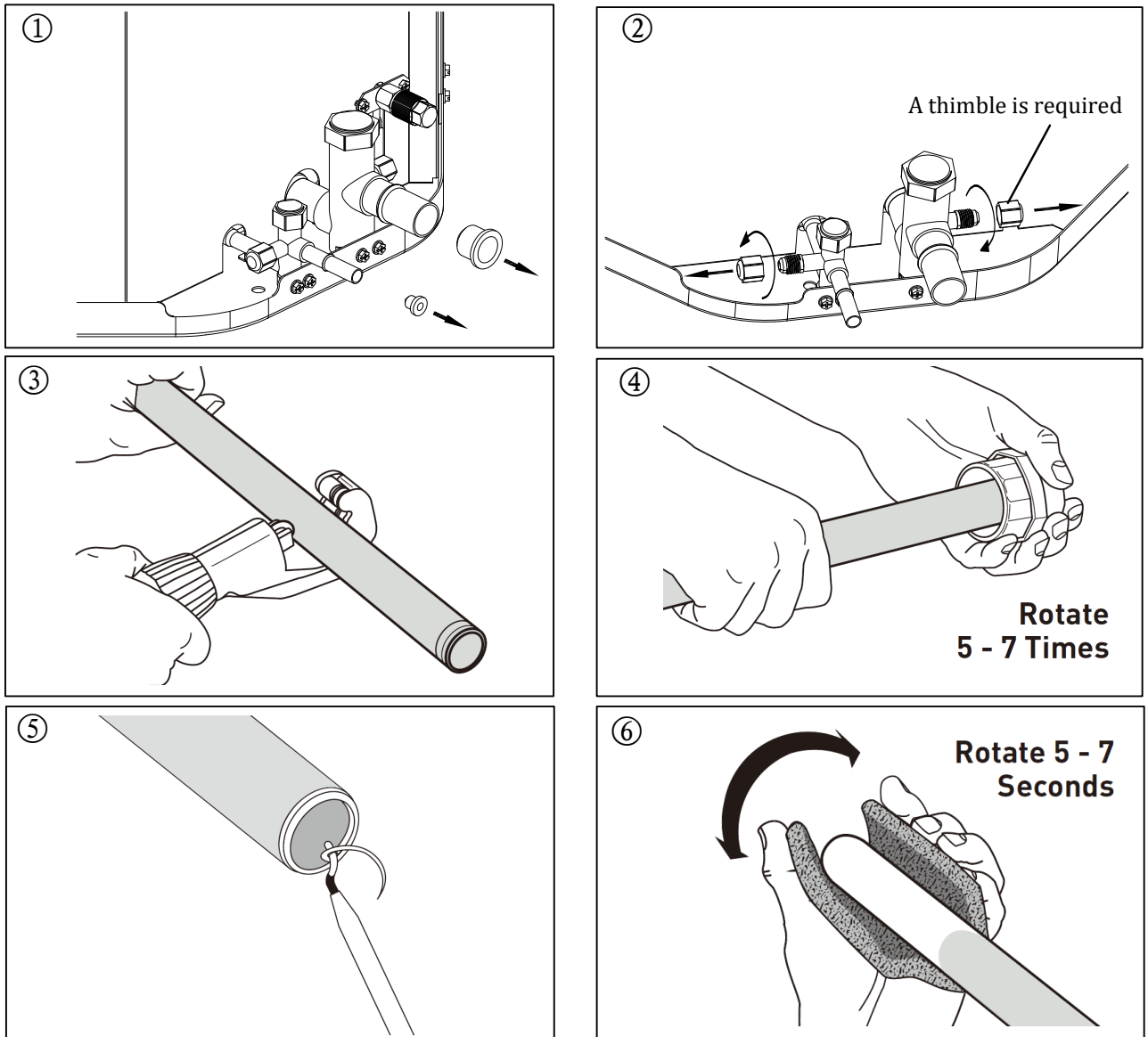

Fig 6-1 Refrigerant Line Brazing Connection

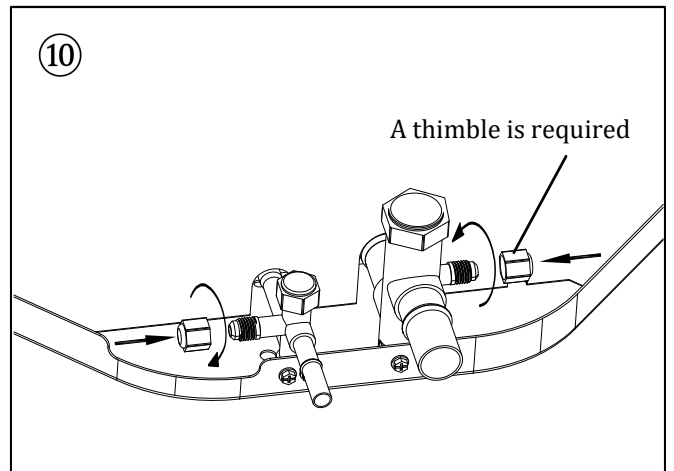
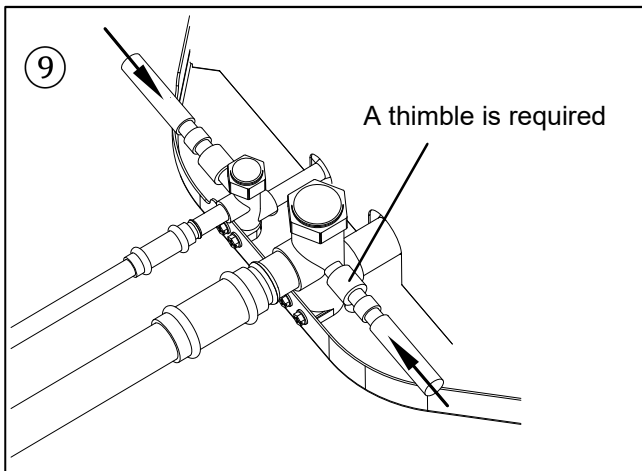
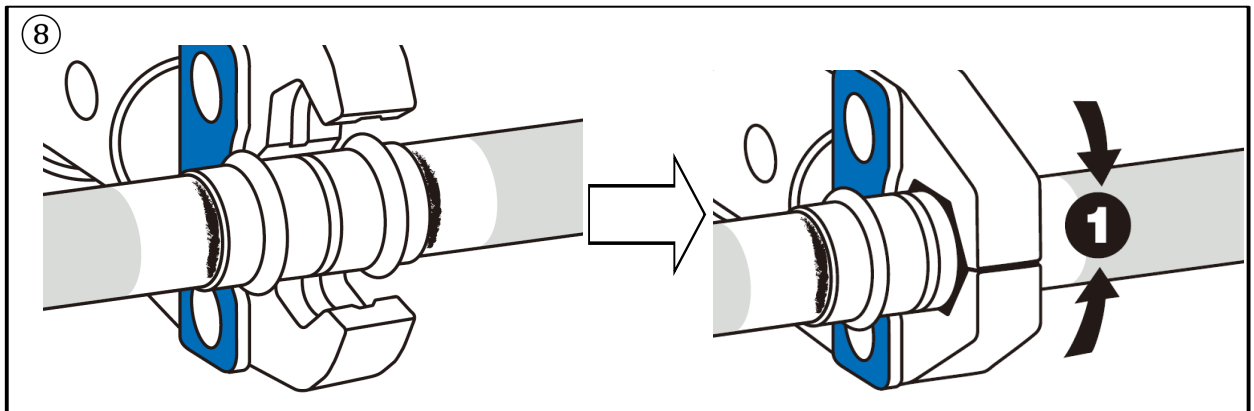
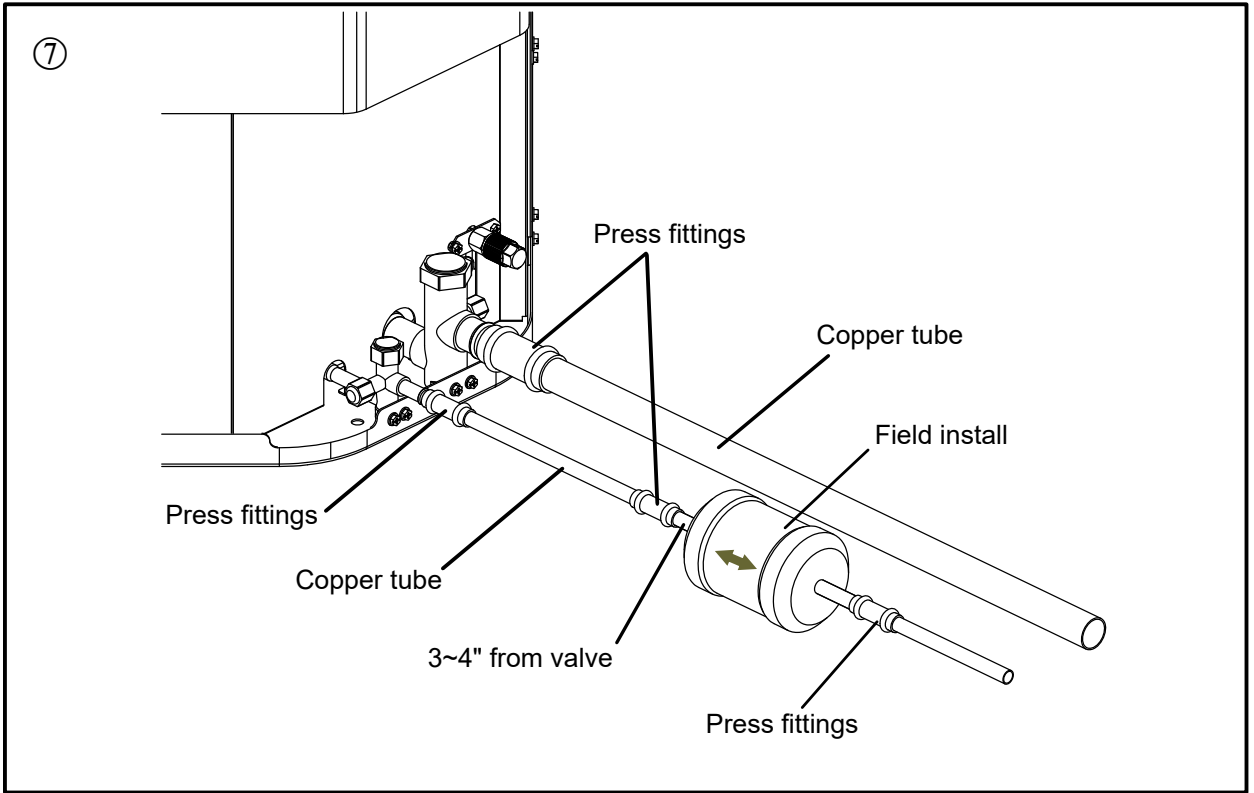

Fig 6-2 Refrigerant Line Press Fitting Connection

6.2 Refrigerant Line Connection

All joints made in the installation between parts of the REFRIGERATING SYSTEM, with at least one part charged, shall be made in accordance with the following:

- A brazed, welded, or mechanical connection shall be made before opening the valves to permit refrigerant to flow between the REFRIGERATING SYSTEM parts. A vacuum valve shall be provided to evacuate the interconnecting pipe or any uncharged REFRIGERATING SYSTEM part.
- Mechanical connectors used indoors shall comply with ISO 14903. When mechanical connectors are reused indoors, sealing parts shall be renewed. When flared joints are reused indoors, the flare part shall be refabricated.
- Refrigerant tubing shall be protected or enclosed to avoid damage.
- Flexible refrigerant connectors (such as connecting lines between the indoor and outdoor unit) that may be displaced during NORMAL OPERATION shall be protected against mechanical damage.

Compliance is checked according to the installation instructions and a trial installation, if necessary.

Field-made refrigerant joints indoors shall be tightness tested. The test method shall have a sensitivity of 5 grams per year of refrigerant or better under a pressure of at least 0.25 times the maximum allowable pressure. No leak shall be detected.

For installations with field applied joints that are exposed in the occupied space these joints shall be at least one of the following:

- Mechanical joints in compliance with ISO 14903 or UL 207 (U.S. only).
- Welded or brazed joints.
- Joints in enclosures that vent to the unit or to the outside.

Compliance is checked by inspection and tests.

7. System Leak Check

Leak check is required for the press fitting line connections.

1. Pressurize the brazed refrigerant lines and indoor coil to at least 450 PSIG using dry nitrogen.
2. Wait for 10 minutes without a drop in pressure.
3. Check for leaks by using a soapy solution or bubbles at each press location.

Note: Remove nitrogen pressure and repair any leaks before continuing.

450PSIG

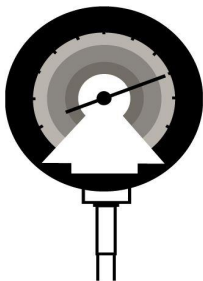

Fig 7-1 Charge the system with dry nitrogen

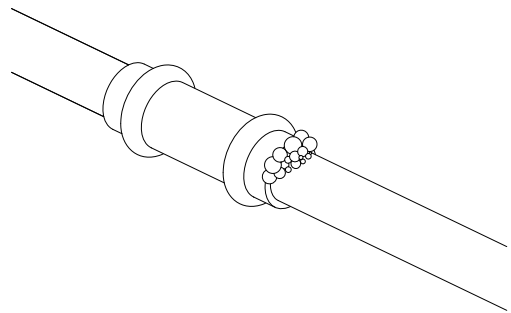

Fig 7-2 Leak check

After completion of field piping for split systems, the field pipework shall be pressure tested with nitrogen and then vacuum tested prior to refrigerant charging, according to the following requirements:

1. The minimum leak test pressure of the lineset and indoor coil shall be the high side design pressure, unless the high side of the system, cannot be isolated from the low side of the system in which case the entire system shall be pressure tested to the low side design pressure.
2. The test pressure after removal of pressure source shall be maintained for at least 1 hour with no decrease of pressure indicated by the test gauge, with test gauge resolution not exceeding 5% of the test pressure.

Important: Under no circumstances shall potential sources of ignition be used in the searching for or detection of refrigerant leaks.

Important: The following leak detection methods are deemed acceptable for all refrigerant systems:

- Electronic leak detectors calibrated for R32
- Bubble method

8. Evacuation and Servicing

8.1 Evacuate the Refrigerant Lines and Indoor Coil

Do not open the service valves until the leak check and evacuation are complete.

1. The vacuum should be pulled for at least 45 minutes.
2. Evacuate until the micron gauge reads less than 350 microns, then close the valve to the vacuum pump.
3. Evacuation is complete if the micron gauge does not rise above 500 microns in 10 minutes.
4. Once evacuation is complete, blank off the vacuum pump and micron gauge, and close the valve on the manifold gauge set.

Under no circumstances shall potential sources of ignition be used in the searching for or detection of refrigerant leaks.

The following leak detection methods are deemed acceptable for all refrigerant systems:

- Electronic leak detectors calibrated for R32
- Bubble method
- Fluorescent method agents

If a leakage of refrigerant is found which requires brazing, all of the refrigerant shall be recovered from the system, or isolated (by means of shut off valves) in a part of the system remote from the leak.

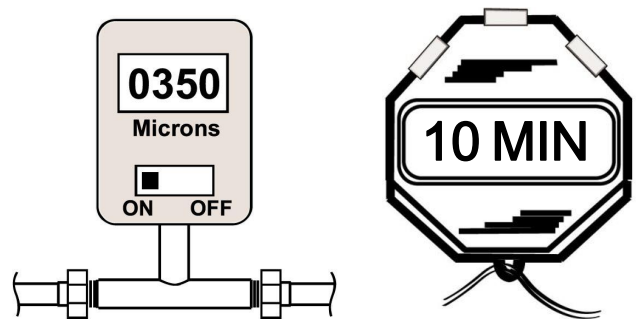

Fig 8-1 Evacuation the refrigerant system

8.2 Servicing

- If repairs must be made after system is charged, properly and safely remove or isolate refrigerant and purge the section of the system needing repair with Nitrogen gas or oxygen free nitrogen prior to opening the circuit.
- The REFRIGERANT CHARGE shall be recovered into the correctly marked recovery cylinders.
- Ensure that the outlet for the vacuum pump is not close to any potential ignition sources and the ventilation is available.
- Prior to recharging the system, it shall be pressure-tested with the appropriate purging gas. The system shall be leak-tested on completion of charging but prior to commissioning. A follow up leak test shall be carried out prior to leaving the site.
- Ensure that only appropriate refrigerant recovery cylinders are employed. Ensure that the correct number of cylinders for holding the total system charge is available. Only use cylinders designated for there covered refrigerant and labelled for the refrigerant. Cylinders shall be complete with pressure-relief valve and associated shut-off valves in good working order.
- A set of calibrated weighing scales shall be available and in good working order. Hoses shall be complete with leak-free disconnect couplings and in good condition. Ensure any associated electrical components are sealed.
- The recovered refrigerant shall be returned to the refrigerant supplier in the correct recovery cylinder. Do not mix refrigerants.
- If compressors or compressor oils are to be removed, ensure that they have been evacuated to an acceptable level to make certain that FLAMMABLE REFRIGERANT does not remain within the lubricant.

9. Service Valves

Leak check and evacuation must be completed before opening the service valves.

The gas service valve must be opened BEFORE opening the Liquid Service Valve!

1. Remove service valve cap.
 2. Fully insert hex wrench into the stem and counterclockwise until valve stem just touches the rolled edge (approximately five turns.)
 3. Replace and tighten the valve stem cap to prevent leaks. Additional 1/6 turn may be required.
- Repeat 1 to 3 for Liquid Service Valve.

 WARNING
<p>Extreme caution should be exercised when opening the Liquid Service Valve. Turn counterclockwise until the valve stem just touches the rolled edge. No torque is required.</p> <p>Failure to follow this will result in abrupt release of system charge and may lead to personal injury and /or property damage.</p>

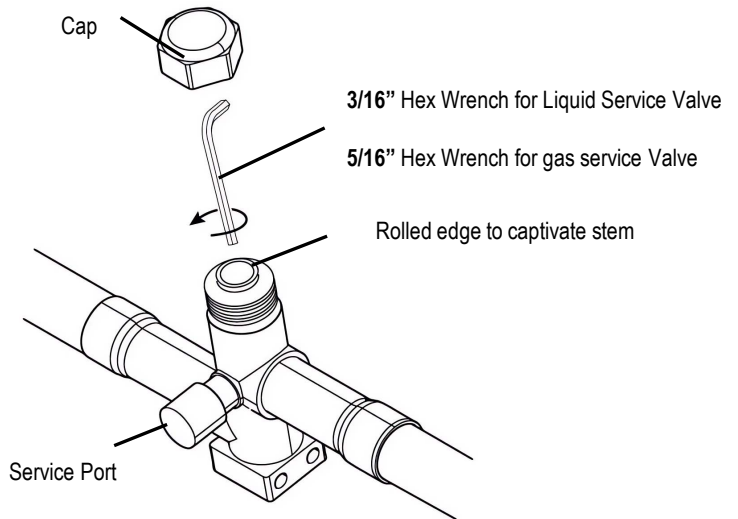

Fig 9-1 Open the service valves

10. Electrical – Low Voltage

10.1 Low voltage wire requirement

Define the maximum length of low voltage wiring from condensing unit to indoor unit and thermostat.

Field installed electrical conduit is required at the low voltage wire entry point. Animals like frogs, snakes, spiders and others may climb into the control box resulting in the MCB damage. **Manufacturer reserves the rights to reject warranty claim on MCB if not comply.**

Table 10-1 Low voltage control wiring requirement

CONTROL WIRING	
Wire Size	Max. Wire Length
18 AWG	150Ft
16 AWG	225Ft

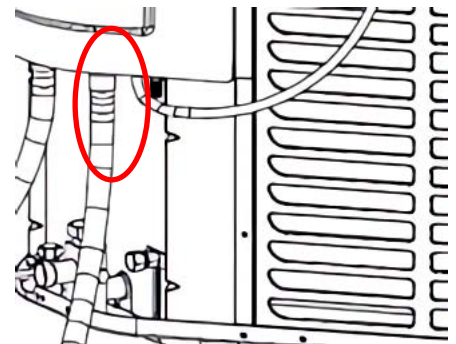

Fig 10-1 Sealing requirement

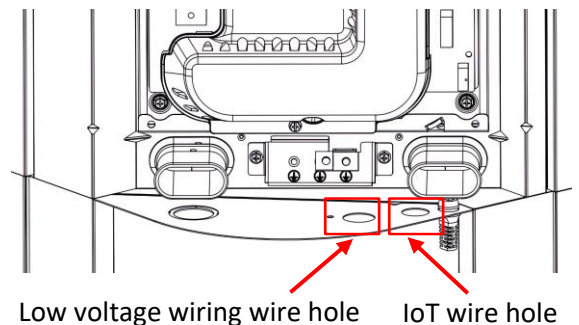

Fig 10-2 Wire hole

10.2 Low voltage hook-up diagrams

With ECOER AHU:

E-heater or Dual fuel

To activate the indoor second heater. Outdoor W terminal outputs 24Vac once the system needs it.

- a. Work when the HP cannot to be started because of $T_a < \text{the value of } n01 \text{ setting}$ in heating.
- b. Work when the second heater is called because $n02 \text{ setting is ON (E-Aux)}$ and $T_a < \text{the value of } n03 \text{ setting}$ in heating.
- c. Work when the HP is in defrosting.

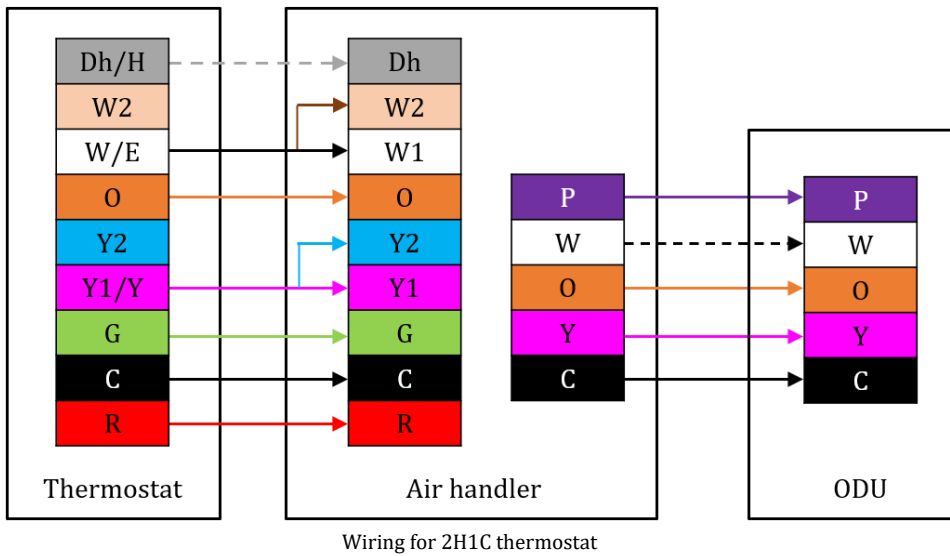
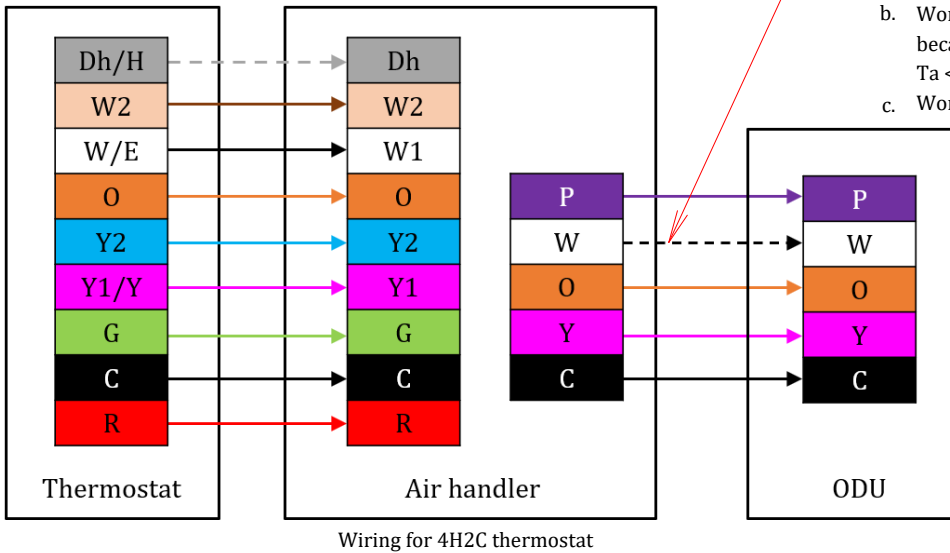

Fig 10-3 Schematic diagram for control wiring connection

NOTES:

1. Be sure power supply agrees with equipment nameplate.
2. Power wiring and grounding of equipment must comply with local codes.
3. Low voltage wiring to be No. 18 AWG minimum conductor.
4. "----" means the electric auxiliary heater connection.

* Some thermostats may use W2/AUX for heat pump.

With third-party AHU:

E-heater or Dual fuel

To activate the indoor second heater. Outdoor W terminal outputs 24Vac once the system needs it.

- a. Work when the HP cannot be started because of $T_a < \text{the value of } n01 \text{ setting in heating.}$
- b. Work when the second heater is called because $n02 \text{ setting is ON (E-Aux)}$ and $T_a < \text{the value of } n03 \text{ setting in heating.}$
- c. Work when the HP is in defrosting.

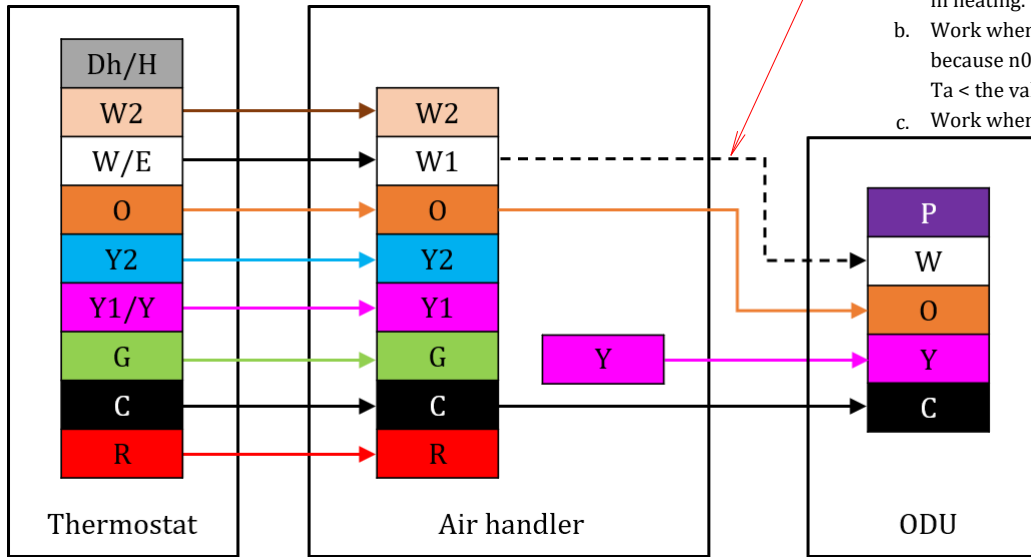

Wiring for 4H2C thermostat

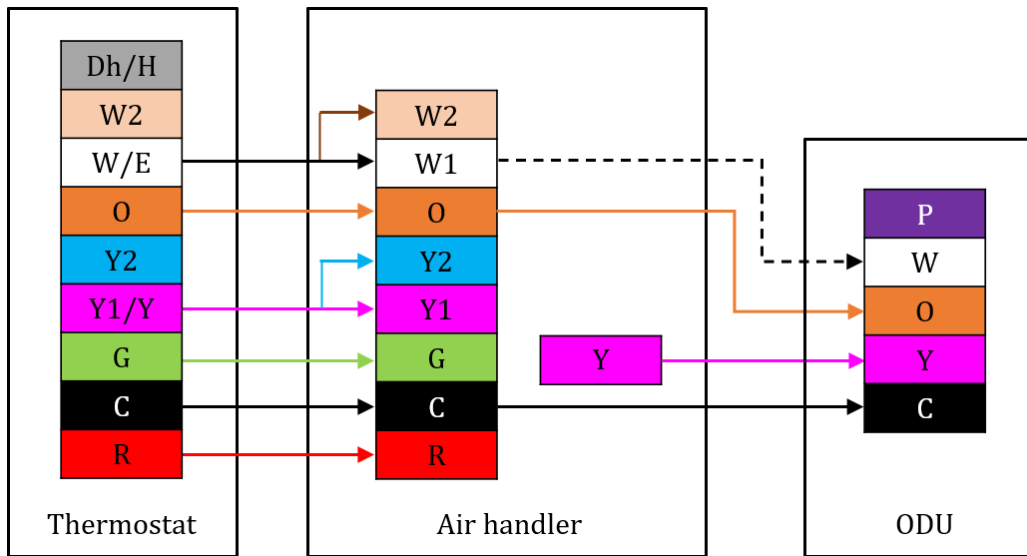

Wiring for 2H1C thermostat

NOTES:

Fig 10-4 Schematic diagram for control wiring connection

1. Be sure power supply agrees with equipment nameplate.
2. Power wiring and grounding of equipment must comply with local codes.
3. Low voltage wiring to be No. 18 AWG minimum conductor.
4. " - - - " means the electric auxiliary heater connection.

* See the installation instructions and requirements of third-party devices on site, the wiring diagram is for reference only. For details, see the actual A2L Control Kit wiring diagram.

* Some thermostats may use W2/AUX for heat pump.

With the Furnace:

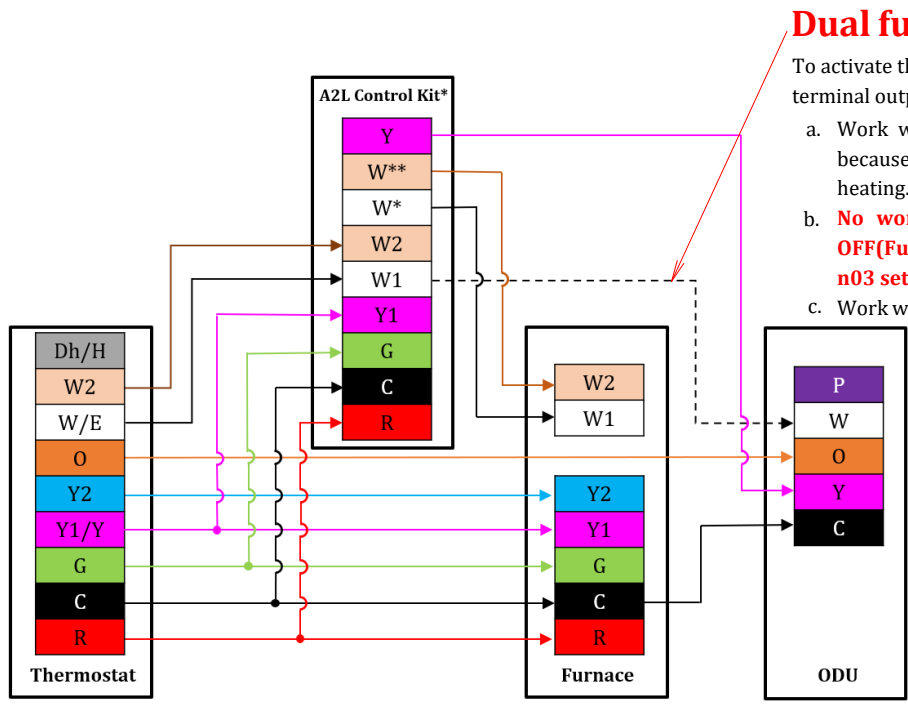

Dual fuel

To activate the second heater. Outdoor W terminal outputs 24Vac once the system needs it.

- a. Work when the HP cannot to be started because of Ta < the value of n01 setting in heating.
- b. **No work when the n02 setting is OFF(Furnace) and regardless of the n03 setting value.**
- c. Work when the HP is in defrosting.

Wiring for 4H2C thermostat (support Dual Fuel)

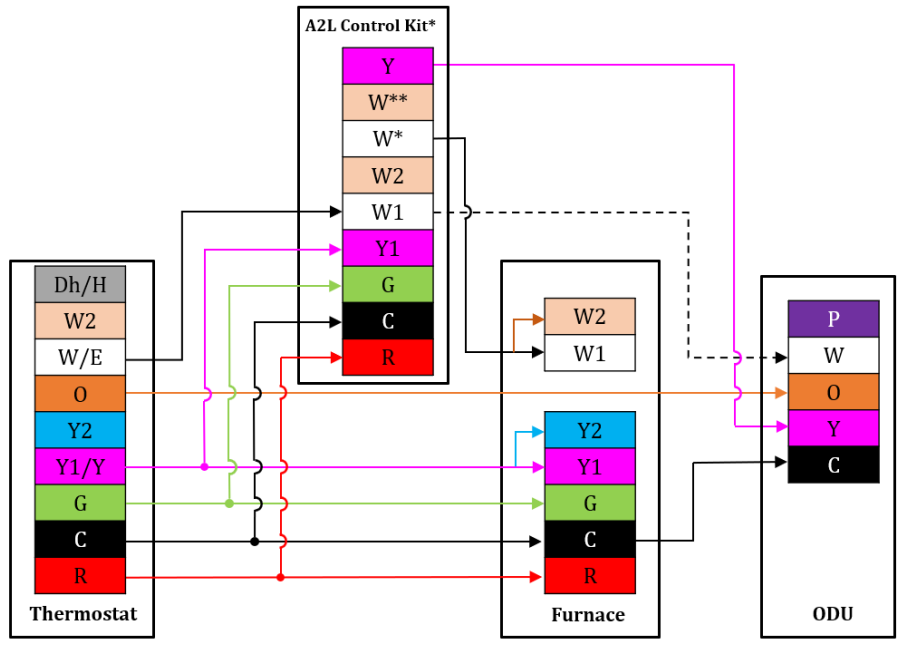

Wiring for 2H1C thermostat (support Dual Fuel)

NOTES:

Fig 10-5 Schematic diagram for control wiring connection

1. Be sure power supply agrees with equipment nameplate.
2. Power wiring and grounding of equipment must comply with local codes.
3. Low voltage wiring to be No. 18 AWG minimum conductor.
4. "--" means the auxiliary heater connection.

* The wiring diagram is for reference only. For details, see the actual A2L Control Kit wiring diagram.

* Some thermostats may use W2/AUX for heat pump.

With the ECOER Cased Coil

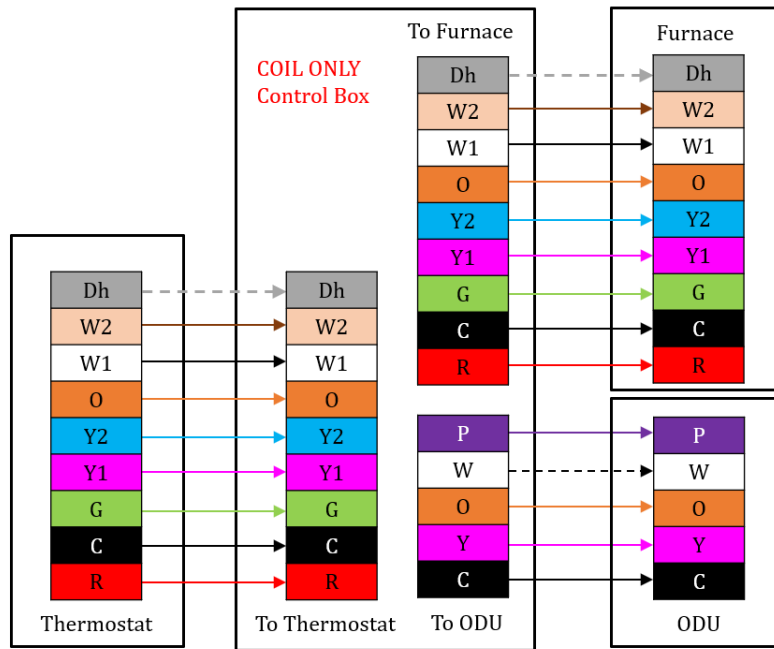

Wiring for 4H2C thermostat

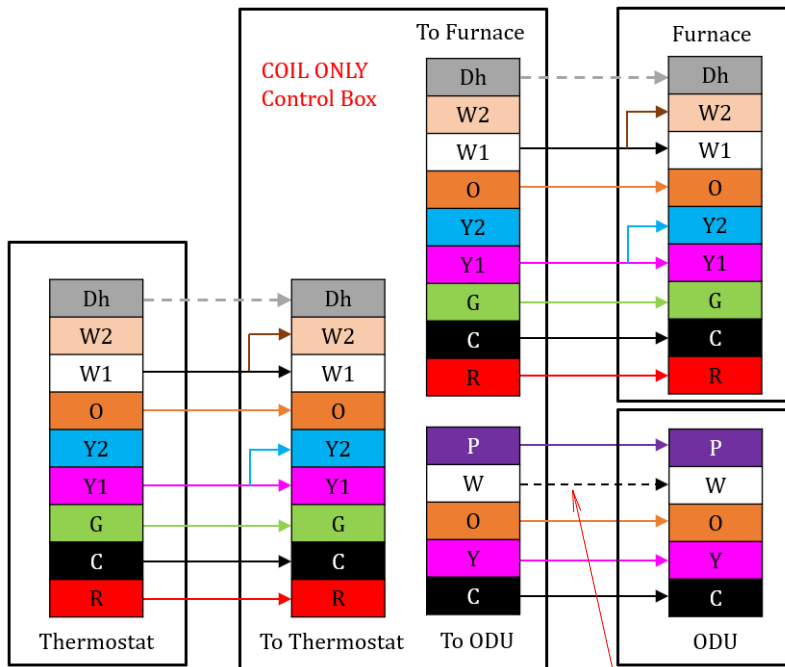

Wiring for 2H1C thermostat

Fig 10-6 Schematic diagram for control wiring connection

NOTES:

1. Be sure power supply agrees with equipment nameplate.
2. Power wiring and grounding of equipment must comply with local codes.
3. Low voltage wiring to be No. 18 AWG minimum conductor.
4. " - - - " means the electric auxiliary heater connection.

- * The wiring diagram is for reference only. For details, see the actual A2L Control Kit wiring diagram.
- * Some thermostats may use W2/AUX for heat pump.

Dual fuel

To activate the second heater. Outdoor W terminal outputs 24Vac once the system needs it.

- a. Work when the HP cannot to be started because of $T_a < \text{the value of } n01 \text{ setting in heating}$.
- b. **No work when the n02 setting is OFF(Furnace) and regardless of the n03 setting value.**
- c. Work when the HP is in defrosting.

11. Electrical – High Voltage

11.1 High voltage power supply

⚠ WARNING

During installation, testing, servicing, and trouble shooting of this product, it may be necessary to work with live electrical components. Failure to follow all electrical safety precautions when exposed to live electrical components could result in death or serious injury.

The high voltage power supply must match the equipment nameplate. Power wiring must comply with National, State and Local codes.

Follow instructions on unit wiring diagram located on the inside of the control box cover.

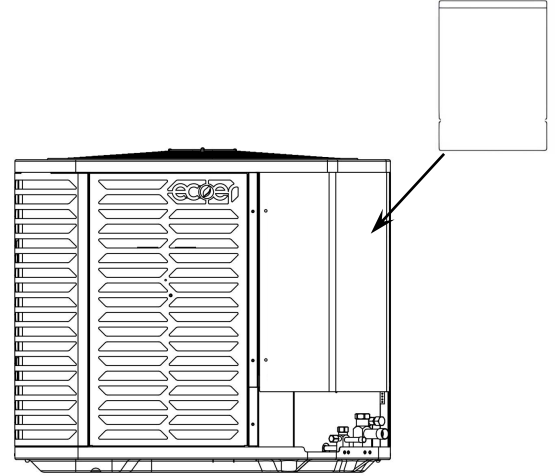

Fig 11-1 Read the Warning Label

Power Supply			
Model	Voltage	MCA	Breaker
2436	208/230V-1Ph-60Hz	24.4A	30A
4860	208/230V-1Ph-60Hz	32.5A	45A

11.2 High voltage disconnect switch

Install a separated disconnect switch at the condensing unit. Field provided **flexible electrical conduit** must be used for high voltage wiring.

In order to get full warranty coverage on the compressor, It is mandatory to install a surge protector to prevent damage to the unit caused by abnormal electrical spikes.

We recommend the Installation of a GFIC (install the GFIC as per your local codes).

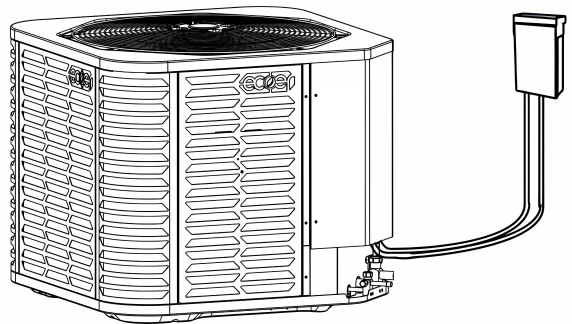
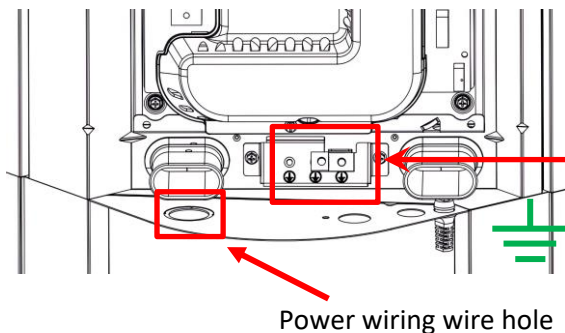

Fig 11-2 Install an independent switch

11.3 High voltage ground

Ground the condensing unit according to National, State, and Local code requirements.



Power wiring wire hole

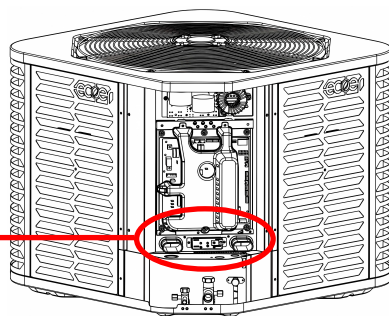

Fig 11-3 Unit grounding

12. Start-up

Prior to start-up the unit, connect IoT device if equipped with. Refer to IoT IM and Registration Guide via ESS Pro App. At the same time, ensure chapters 5 to 11 have been completed.

1. Set the thermostat to OFF.



2. Turn on disconnect switch to apply power to the indoor and outdoor units.

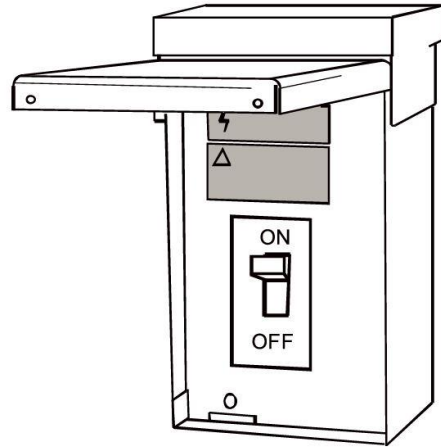

3. Wait 40 minutes before starting the unit if the outdoor ambient temperature < 59 °F.



4. Set the thermostat to ON.

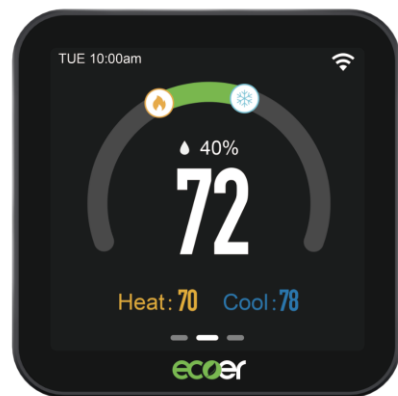

NOTE:

It may take up to 45 minutes for the heating operation to exit start-up control the first time. This is normal function to preheat lubricants in the bottom of compressor.

13. System Charge Adjustment

13.1 Weigh-in method

Weigh-in method can be used for the initial installation, or anytime a system charge needs to be replaced. Weigh-in method can also be used when power is not available on the job site or the ambient temperature is improper to use refrigerant coefficient and sub-cooling charge method.

When using weigh-in method in heating mode, be sure the compressor discharge superheat (DSH) meets the target value. Basically, the liquid line sub-cooling (SC) shall not exceed 30°F.



Use the **gauge port** to charge the system in heating mode and query live data using the BS3 button to calculate DSH (The difference between parameter “11” and “18”) or check SC/DSH via ESS Pro App.

Table 13-1 Charge amount table

A	B	C		D
Model	Factory charge	Indoor	Charge amount for ecoer air handler	Charge multiplier for liquid line length *2
2436	The data on nameplate	24K	0	0.6 oz/ft
		36K	0	
36K		0		
48K		11oz *1		
60K		11oz *1		
4860				

- 1. Every condensing unit is factory charged for the smallest rated indoor coil combinations.** An additional amount of refrigerant adjustment is required for a large indoor coil. It's invalid for system with electric heat or other third-party heat source whose capacity is 1.2 times of heat pump nominal capacity.
- 2. The charging guideline is calculated in 25ft of standard size line set.** A refrigerant adjustment may be necessary if the line set length is over the pre-charged 25 ft (adding 0.6 oz/ft on 3/8 liquid line respectively).

13.2 Auto charge mode

NOTES:

1. This AUTO charge mode is suitable for ambient temperature between 50°F and 115°F. But for the best results, indoor temperature should be kept between 70°F and 80°F. For outdoor ambient temperature is below 50°F, use weigh-in charge method only.



Fig 13-1 Temperature limit for AUTO charge mode

2. Start-up control is enforced to complete prior to activate the AUTO charge mode. It may take 4 to 10 minutes to exit start-up control procedure and fix the compressor speed (RPS).
3. The service valve is usually closed except in charge mode. If you need to know the suction pressure, you can log in to ESS Pro, or read the parameter of "07" from Spot check.

Enter the charge mode

Turn on the power supply for the system, select **cooling mode** at thermostat. Make sure the setting temperature is lower than indoor temperature for at least 5°F to finish this charge mode ***NOTE1**.

Press and hold BS4 button for five (5) seconds until SEG1 displays blinking 7. After one minute, the system will go into AUTO charge mode ***NOTE2**.

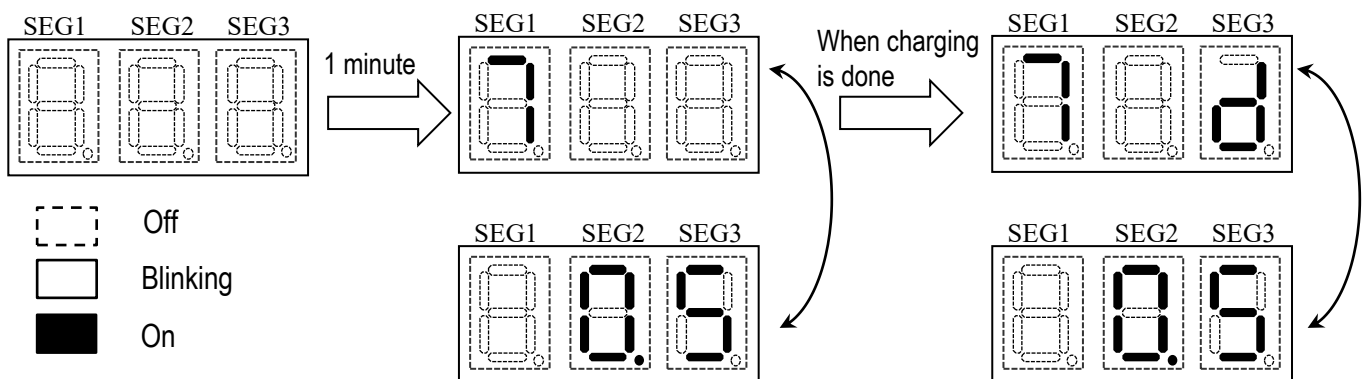
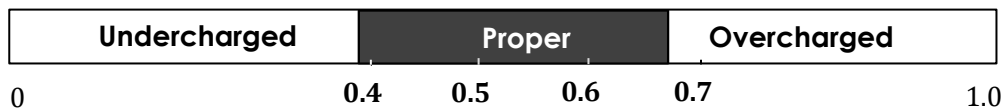

Fig 13-2 LED display in AUTO charge mode

Run the system for more than 15 minutes and will show the **refrigerant coefficient** number (here short for "X", $0 < X < 1$) from the LED display. If keep $X > 0.5$ for more than 5 minutes, the LED display will show more "d", which means "done"; or $X < 0.5$, the system need to be charged more refrigerant by manual control and Continuously make judgments until the charging is done. Kindly, if $X < 0.4$, refrigerant charging is recommended. Basically, charging is in the case of $9^{\circ}\text{F} \leq \text{SSH} \leq 20^{\circ}\text{F}$, otherwise automatic charging judgments may be affected, if it occurs need to check the cooling throttling device. **When the LED displays "--" for more than 20 minutes in cooling, stop charging and check that the evaporator throttle valve of the indoor unit is working correctly.**

Refrigerant coefficient

The refrigerant coefficient is used to evaluate the refrigerant level in the ecoer system.



Use either way below to end AUTO charge mode

Press **BS4 once**/ After 2 hours running (Automatically EXIT)/ Turn off the system at thermostat

13.3 Sub-cooling charge

Refer to the following steps to charge refrigerant by sub-cooling degree in cooling mode.

STEP1 CALCULATE SUPERHEAT ON SUCTION VALVE

Measured suction line temperature = _____ °F

Measured suction line pressure = _____ PSIG

Calculated superheat value = _____ °F

Table 13-2 Superheat calculation on gas service valve

Suction line TEMP (°F)	Final Superheat (°F)							
	8	10	12	14	16	18	20	22
	Suction Gauge Pressure (PSIG)							
40	103	99	95	92	88	84	80	77
42	108	103	99	95	92	88	84	80
44	112	108	103	99	95	92	88	84
46	116	112	108	103	99	95	92	88
48	121	116	112	108	103	99	95	92
50	126	121	116	112	108	103	99	95
52	131	126	121	116	112	108	103	99
54	136	131	126	121	116	112	108	103
56	141	136	131	126	121	116	112	108
58	146	141	136	131	126	121	116	112
60	151	146	141	136	131	126	121	116
62	157	151	146	141	136	131	126	121
64	162	157	151	146	141	136	131	126
66	168	162	157	151	146	141	136	131
68	174	168	162	157	151	146	141	136
70	180	174	168	162	157	151	146	141
72	186	180	174	168	162	157	151	146

STEP2 CALCULATE SUB-COOLING ON LIQUID VALVE

Measured liquid line temperature = _____ °F

Measured liquid line pressure = _____ PSIG

Calculated sub-cooling value = _____ °F

Add refrigerant if calculated sub-cooling value is lower than the designed one. Repeat the steps above.

Table 13-3 Sub-cooling calculation on liquid service valve

Liquid line TEMP (°F)	Final Sub-cooling (°F)							
	6	7	8	9	10	11	12	13
	Liquid Gauge Pressure (PSIG)							
55	177	180	183	186	190	193	196	199
60	193	196	199	203	206	209	213	216
65	209	213	216	220	223	227	231	234
70	227	231	234	238	242	245	249	253
75	245	249	253	257	261	265	269	273
80	265	269	273	277	281	286	289	294
85	286	289	294	299	303	307	312	317
90	307	312	317	321	326	330	335	340
95	330	335	340	345	350	355	360	365
100	355	360	365	370	375	380	385	391
105	380	385	391	396	401	407	412	418
110	407	412	418	423	429	435	441	447
115	435	441	447	453	459	465	471	477
120	465	471	477	483	490	496	502	509
125	496	502	509	515	522	528	535	542

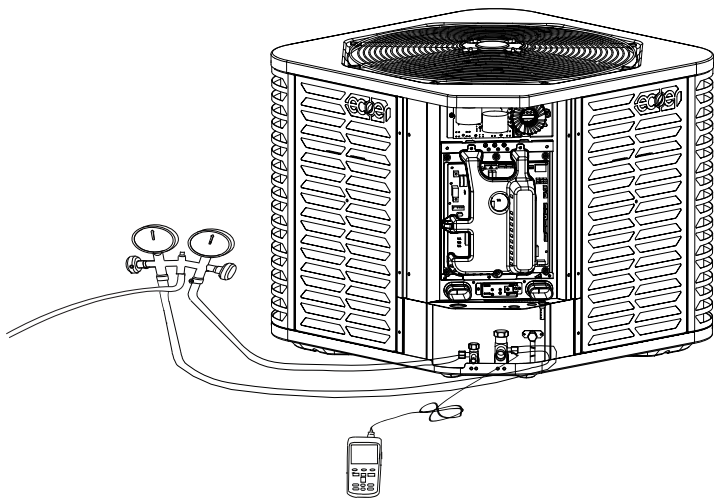

Fig 13-3 Measure the superheat or sub-cooling

Table 13-4 Designed sub-cooling degree

Model	Designed sub-cooling degree (SC)
24	8°F (±2°F)
36	10°F (±2°F)
48	10°F (±2°F)
60	10°F (±2°F)

STEP3 ADJUST REFRIGERANT LEVEL TO ATTAIN PROPER GAUGE PRESSURE

Add refrigerant if the sub-cooling is lower than the chart value.

1. After each charging operation, wait for 5 to 10 minutes until it stabilizes, and ensure that SSH is greater than 10°F. Then repeat the charging operation if need. When the sub-cooling matches the chart, the system is properly charged.
2. Purge all hoses.
3. Stand the refrigerant tank upside-down and charge.
4. Stop adding refrigerant when sub-cooling matches the charging chart.

Remove refrigerant if the sub-cooling is higher than the chart value.

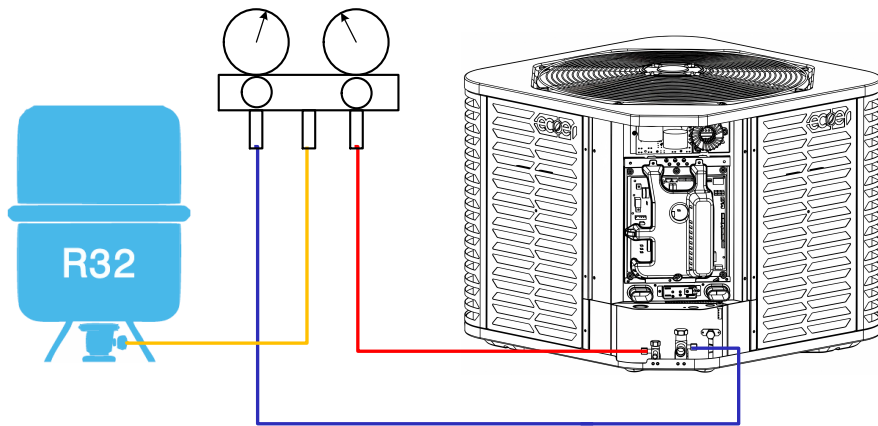

STEP4 STABILIZE THE SYSTEM

1. Wait five (5) minutes for the unit to stabilize between adjustments. When the sub-cooling matches the chart, the system is properly charged.
2. Remove gauge hoses.
3. Replace and tighten service port caps to prevent leaks. Plus an additional 1/6 turn may be required.

STEP5 RECORD SYSTEM INFORMATION FOR FURTHER REFERENCE

Condensing unit model	
Indoor unit model	
Measured outdoor ambient temperature	°F
Measured indoor ambient temperature	°F
Liquid gauge pressure	PSIG
Suction gauge pressure	PSIG
Measured suction line temperature	°F
Measured liquid line temperature	°F

14. System Operation

14.1 Default display

LED on main control board can display the operating status of outdoor unit (ODU).



SEG1: Normally blank, but it displays codes “0 to 9” accordingly if there is damaged sensor and command response.

SEG1 Code	Description
0	Software is updating through IoT device
1	High pressure sensor (HP) fault backup running
2	Low pressure sensor (LP) fault backup running
3	Compressor discharge temperature sensor (TD) fault backup running
4	IPM module temperature sensor (TF) fault backup running
5	Ambient temperature sensor (TA) fault backup running
6	Defrost sensor (TH) fault backup running
7	Compressor suction temperature sensor (TS) fault backup running
8	Liquid line temperature sensor (TL) fault backup running
9	IoT command response

SEG2: Normally blank, but it will display code accordingly as below if outdoor unit is running under limited condition.

SEG2 Code	Description
0	Running under high pressure limit
1	Running under low pressure limit
2	Running under discharge temperature limit
3	Running under IPM module temperature limit
4	Running under compressor current limit

SEG3: It displays outdoor unit’s operation mode.

SEG3 Code	Description
0	Stop (Y signal de-energized)
1	Ready to start-up *NOTE
2	Cooling
3	Heating
4	Oil return
5	Defrost
6	Manual defrost
7	AUTO charge mode in cooling
8	Pump down

NOTE: Compressor waits three to eight (8) minutes to restart.

Mode list (SEG3 Display)

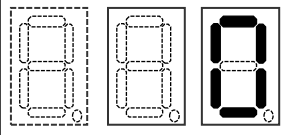
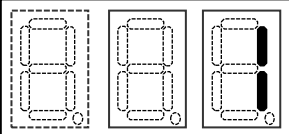
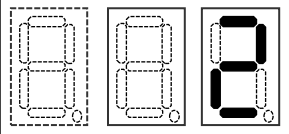
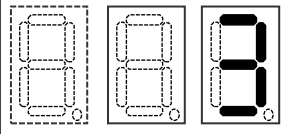
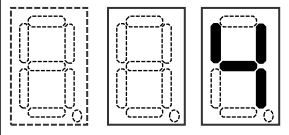
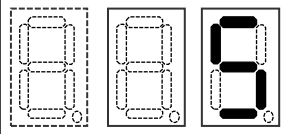
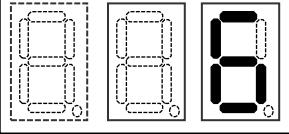
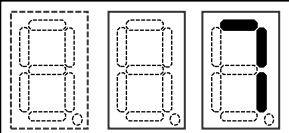
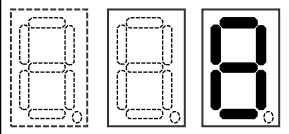
<p>Stop or standby</p>	<p>SEG1 SEG2 SEG3</p> 
<p>Ready to start-up</p>	<p>SEG1 SEG2 SEG3</p> 
<p>Cooling</p>	<p>SEG1 SEG2 SEG3</p> 
<p>Heating</p>	<p>SEG1 SEG2 SEG3</p> 
<p>Oil return</p>	<p>SEG1 SEG2 SEG3</p> 
<p>Defrost</p>	<p>SEG1 SEG2 SEG3</p> 
<p>Manual defrost</p>	<p>SEG1 SEG2 SEG3</p> 
<p>AUTO charge mode in cooling</p>	<p>SEG1 SEG2 SEG3</p> 
<p>Pump down</p>	<p>SEG1 SEG2 SEG3</p> 

14.2 Field setting

Outdoor condensing units' functions can be applied by dipping switch and pressing buttons.

14.2.1 Setting by dip switches

SW1 Dip switch		Description	
NO.	Setting item	Status	Content
1	Snow Sensor Control	ON	Disable
		OFF (factory)	Enable
2	Capacity selection	ON	2 or 4 Ton
		OFF (factory)	3 or 5 Ton
3	AC only / Heat pump	ON	AC only
		OFF (factory)	Heat pump
4	Command ^{*a} response for IoT	ON	Disable
		OFF (factory)	Enable

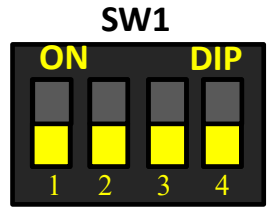

Use minor straight screwdriver to dip switch. Must power off the unit for at least two minutes to activate the change.

a. Remote field setting, troubleshooting, software programming etc.

14.2.2 Setting by pressing buttons

Query and setting operation can be done by pressing buttons on main control board.

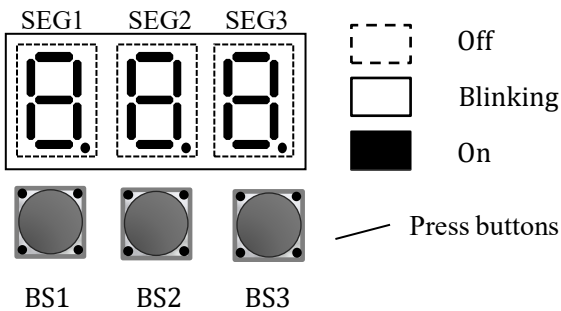

BS1: Menu or back button

BS2: UP button

BS3: Spot check and confirm button

Remarks:

Press or tip any directions are valid.

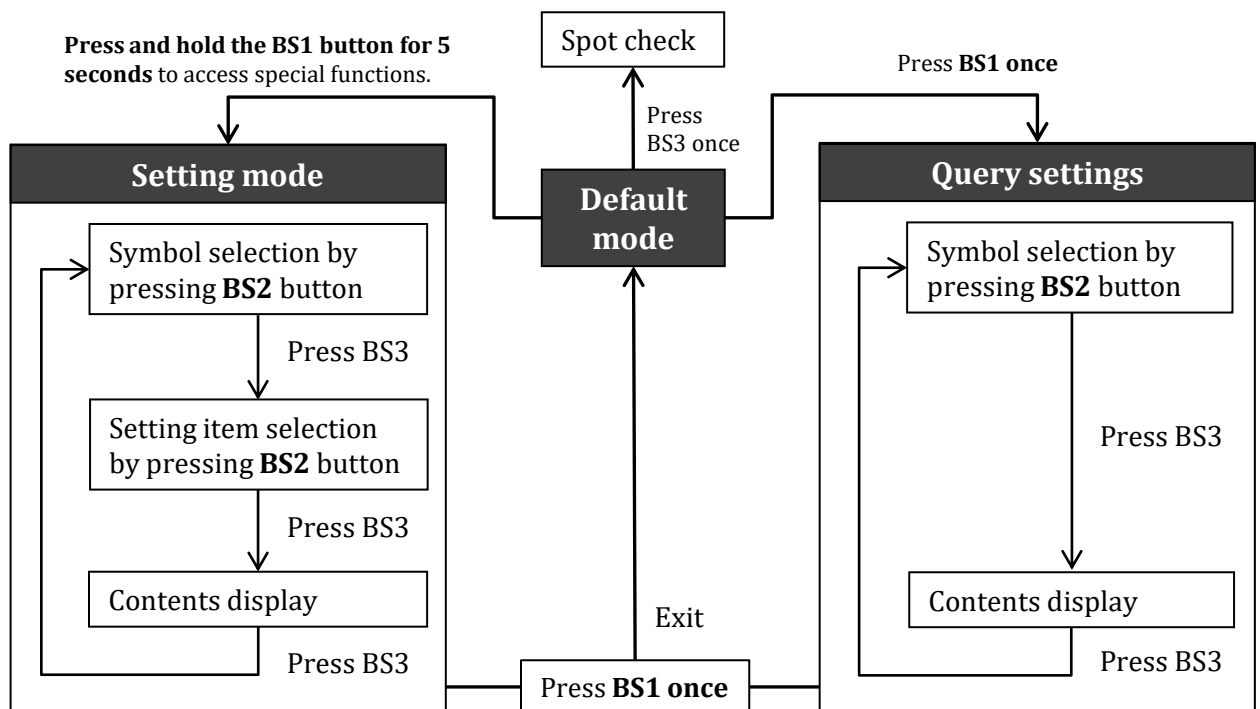

Default mode (Spot check)

System states can be showed on the 7 segments display (LED) of outdoor unit. Press the **BS3** button to obtain the code number and corresponding information at one-second intervals.

Example: Code number

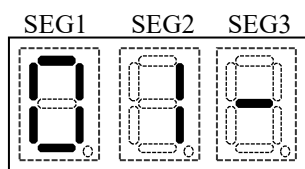

Detailed information

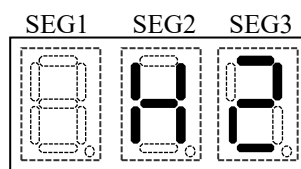

No.	Number content	Example	Description
Default	Refer to default display instructions	902	9: Command/Troubleshooting 0: Running under high pressure limit 2: Cooling mode
01-	Outdoor unit type and capacity	H3	H: Heat pump C: AC only 3: 3Ton
02-	Liquid line sub-cooling	10	10°F
03-	Compressor suction superheat	18	18°F
04-	Compressor speed	56	56RPS
05-	Electronic expansion valve opening	360	360pls
06-	Step of fan	8	The 8th step
07-	Low pressure (LP sensor)	145	145psig
08-	High pressure (HP sensor)	350	350psig
09-	Outdoor ambient temp. (TA)	95	95°F
10-	Compressor suction temp. (TS)	70	70°F
11-	Compressor discharge temp. (TD)	170	170°F
12-	Defrost sensor temp. (TH)	80	80°F
13-	Liquid line temp. (TL)	70	70°F
14-	Inverter module temp. (TF)	150	150°F
15-	Target evaporating temp. (Tes)	43	43°F
16-	Current evaporating temp. (Te)	45	45°F
17-	Target condensing temp. (Tcs)	104	104°F
18-	Current condensing temp. (Tc)	112	112°F
19-	Compressor DC current	10.1	10.1A
20-	Undercharged refrigerant signal	1	0: None 1: Level 1 2: Level 2
21-	Main software version	701	Ver 701
22-	Inverter software version	38	Ver 38
23-	Current fault	E1	Display up to 5 * codes
24-	The last fault	F1	--: none
25-	Fault before the last fault	F2	--: none
26-	Product series	7	TDi Select 2

Remarks: When multi-error codes exist at the same time, each code will be displayed one by one with an interval of one (1) second.

Setting mode

Press and hold **BS1** button for five (5) seconds to enter the parameter setting interface. The latest setting will be taken as the final one.

Symbol	Function	Item	Description
n00	Mode choice	0 (factory)	Normal (Energy Saving) mode
		1	Dry mode *1
		2	High capacity mode *2
n01	Forced heat pump stop when ambient temperature is lower than specified value. Switching to heat by gas furnace or boiler in cold winter.	0	Stop heat pump when TA<-22°F
		1 (factory)	Stop heat pump when TA<-5°F
		2	Stop heat pump when TA<15 °F
		3	Stop heat pump when TA<30 °F
		4	Stop heat pump when TA<40°F
		5	Stop heat pump when TA<20°F
		6	Stop heat pump when TA<25°F
		7	Stop heat pump when TA<35°F
n02	Indoor second heater for outdoor unit outputs 24VAC at W terminal (CN5).	0 (factory)	ON (Electric auxiliary heater)
		1	OFF (Furnace or Boiler)
n03	Outdoor unit outputs 24VAC at W terminal (CN5) when ambient temperature is lower than specified value to start indoor electric auxiliary heater.	0 (factory)	TA<15°F (24VAC output)
		1	TA<30°F (24VAC output)
		2	TA<40°F (24VAC output)
		3	TA<-5°F (24VAC output)
		4	OFF
		5	TA<20°F (24VAC output)
		6	TA<25°F (24VAC output)
		7	TA<35°F (24VAC output)
n04	Defrost mode setting *3	0	Defrost in heavy snow area
		1 (factory)	Standard mode
		2	Defrost in light snow area
n05	Silent mode setting	0 (factory)	None silent mode
		1	Silent mode (level 1)
		2	Super silent mode (level 2)
		3	Night silent mode (level 1)
n06	Night silent setting- start time	4	Night super silent mode (level 2)
		0	17:00
		1 (factory)	18:00
		2	19:00
n07	Night silent setting- end time	3	20:00
		4	21:00
		0	5:00
		1 (factory)	6:00
		2	7:00
		3	8:00
		4	9:00

Symbol	Function	Item	Description
n08	Forced defrost	0 (factory)	OFF
		1	ON *4
n18	Product Series setting	7	TDi Pro 2 series

Remarks:

1. The evaporating temperature of indoor coil can drop down to 28°F.
2. The evaporating temperature of indoor coil can drop down to 28°F in cooling mode, and the condensing temperature can go up to 122°F in heating mode.
3. Reduce about 10% heating time for heavy snow area, increase about 10% heating time for light snow area.
4. System enters defrost after the heating start-up and an extra five minutes.

14.3 Major components function

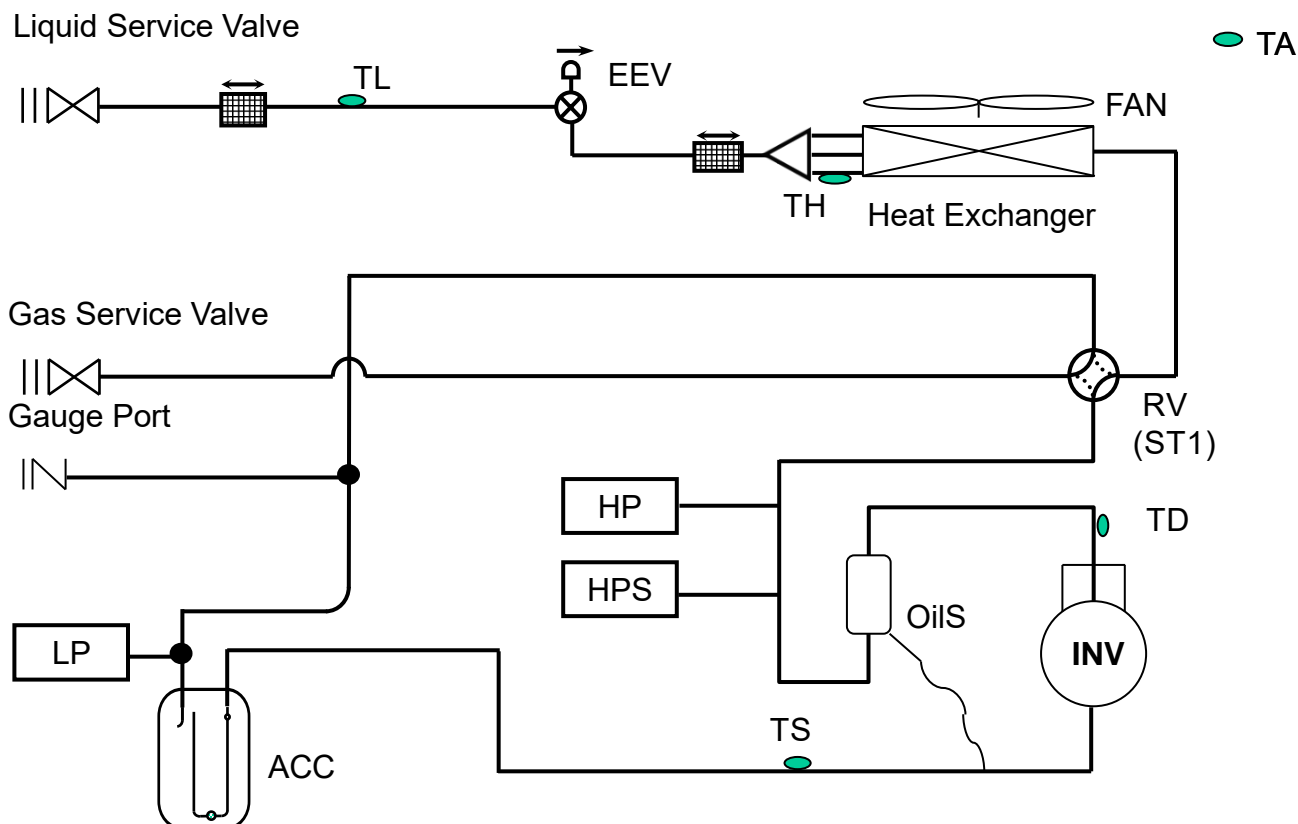

Name	Symbol	Function
Inverter compressor	INV	Adjusts refrigerant flow rate by changing the speed (RPS) based on objective pressure.
Oil separator	OilS	The compressor oil is collected and returned to the compressor.
Outdoor fan	FAN	Outputs heat exchanger capacity by adjusting the motor rotation speed based on operating pressure.
Electronic expansion valve	EEV	1) Fully open in cooling mode and defrost operation. 2) Control compressor discharge superheat in heating mode.
Reversing valve	RV (ST1)	Switches the operation mode between heating and cooling (including defrost control).
Temperature sensor	TH	Uses to control defrost during heating operation.
	TA	Uses to detect outdoor air temperature and control fan speed.
	TS	Uses to detect compressor suction temperature and calculate compressor suction superheat (SSH).
	TL	Uses to detect liquid line temperature and calculate sub-cooling (SC).
	TD	Uses to detect compressor discharge temperature and calculate discharge superheat (DSH).
	TF	Uses to detect heat sink temperature of inverter module.
High pressure sensor	HP	Uses to detect high pressure.
Low pressure sensor	LP	Uses to detect low pressure.
Accumulator	ACC	Uses to store excess refrigerant.
High pressure switch	HPS	Uses to high pressure protection

14.4 Control logic description

14.4.1 Operation mode

SW1_3=OFF (factory), the system operates the heat pump function.

SW1_3=ON, the system run cooling only.

Normal operation:

Compressor control / EEV control / Fan motor control / Protection control
 More detailed information can be found on Ecoer-TDi-Pro2 service manual.

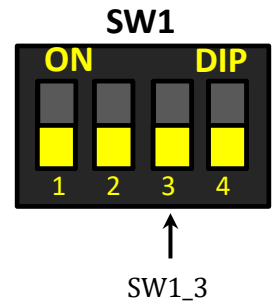

14.4.2 Compressor control

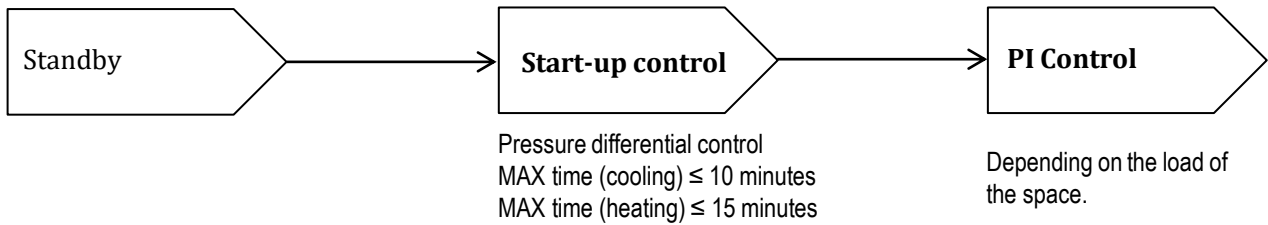

Outdoor Capacity	2ton	3ton	4ton	5ton
Cooling/Heating Min RPS	20	20	20	20
Cooling Max RPS	66	80	66	74
Heating Max RPS	98	112	94	104

14.4.3 Outdoor electronic expansion valve (EEV) control

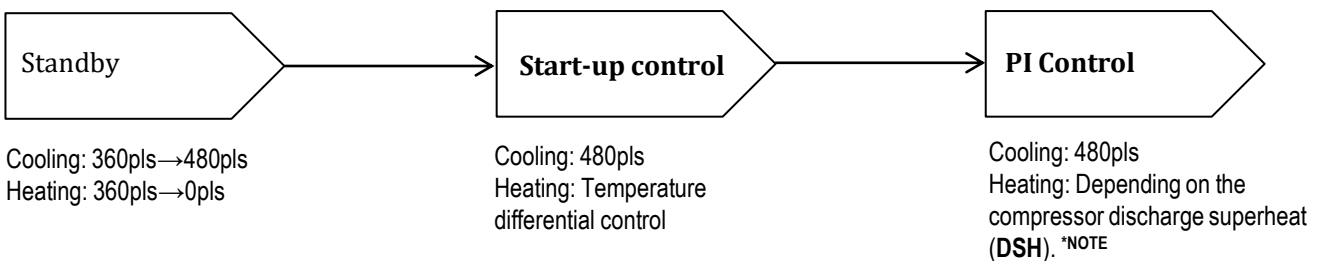

NOTE: Heating DSH should be between 25°F and 60°F with proper refrigerant level.

- **Overcharged:** DSH is less than 18 °F with EEV opening < 72pls.
- **Undercharged:** DSH is higher than 80 °F with EEV opening ≥ 460pls

14.4.4 Defrost control

This system carries out demand defrost control if any one of the following conditions is satisfied.

I. The calculated temperature difference between ambient temperature (TA) and defrost temperature (TH) is called Delta T. After Delta T is achieved and continues for 5 minutes.

- a) TA is between 41°F and 59°F : TH ≤ 30°F, Delta T = 18°F
- b) TA is between 19°F and 41°F : TH ≤ 30°F, Delta T = 12~18°F
- c) TA is less than 19°F : TH < 9°F, accumulative compressor run time ≥ 80 minutes

TH back-up running: TA < 59°F and LP ≤ 90PSIG, accumulative compressor run time ≥ 60 minutes

II. After “Minimum Run Time” (MRT) is achieved.

- a) MRT is 3.5 hours if TA is less than 23°F
- b) MRT is 2 hours if TA is between 23°F and 43°F

III. The high pressure drops below 245PSIG for 20 minutes if TA is between 14°F and 28°F.

EXIT :

Defrost will be terminated once defrost temperature sensor (TH) reaches 64°F for one (1) minute or the defrost time has exceeded eight (8) minutes.

SETTING :

Defrost mode setting (n04) offers termination options for different geographical conditions.

- a) Defrost in heavy snow area will extend defrost for one (1) minute, but reduce the heating time to execute more defrost cycles.
- b) Defrost in light snow area will reduce defrost for 30 seconds.

14.4.5 Manual Defrost

Manual defrosting mode can be used when verifying defrosting or forcing defrosting.

Note: After 5-10 minutes of continuous heating operation, the unit can respond to manual defrosting in time; otherwise, the unit will enter after meeting the requirements.

Enter in either way:

- a. n08 setting;
- b. Hold on BS1+BS2 for more than 5 seconds, release and wait about 1 minute.

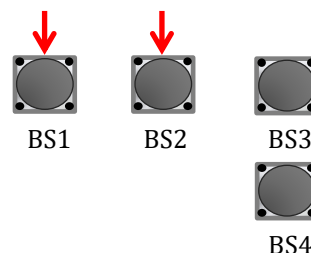

Exit in either way:

Defrost exit automatically/Heating demand off/Power off

15. Troubleshooting

If the system does not operate properly or if there are any malfunctions. Check the system based on the following procedures.

Symptoms	Possible causes	Solutions
System does not start-up but the digital tube shows normally	<ul style="list-style-type: none"> No 24 VAC for Y signal from thermostat. Incompatible thermostat 	<ul style="list-style-type: none"> Be sure Y/O/C wirings are connected correctly and the cooling/heating setting temperature at thermostat is proper Use other traditional 24VAC thermostats
System operates mode reversely	<ul style="list-style-type: none"> Incorrect O/B signal selection 	<ul style="list-style-type: none"> Choose O for cooling at thermostat
System cannot cool well	<ul style="list-style-type: none"> Outside temperature is too high Outside temperature is too low Dirty air filter or blocked duct Lack of refrigerant Refrigerant has been blocked in the condenser coil 	<ul style="list-style-type: none"> Normal protection control to limit RPS Ensure the cooling loads Replace the air filter and eliminate any obstacles. Check refrigerant amount or any leaks. Counterclockwise the TXV (Make sure the refrigerant coefficient is 0.6)
System cannot heat well	<ul style="list-style-type: none"> Outside temperature is too low but no third-party heat inside The outdoor coil is dirty or has been covered by heavy snow Dirty air filter Micro channel coil has been used for heat pump Lack of refrigerant 	<ul style="list-style-type: none"> Install auxiliary heat for backup *Dual-heating is recommended Clean the outdoor coil Replace the air filter No micro channel coils shall be used for heat pump Check refrigerant amount or any leaks

Remarks:

Ecoer systems are compatible with most traditional 24VAC thermostats.



CAUTION

Reversing valve is energized (208/230VAC) in heating mode.

Error codes List for Condensing Unit

Error codes can be inquired by BS3 button, and seen on Ecoer Smart Service Pro App. **Sign in App >Files >Service, refer to Ecoer Decades Pro service manual for troubleshooting details.**

Code	Description	Legend
P1	High pressure protection	
E1	System locks up when P1 has occurred six times in 3 hours.	Cannot restart *1
P2	Low pressure protection in cooling mode	
E2	System locks up when P2 has occurred six times within 3 hours.	Cannot restart *1
P3	Compressor discharge temperature (TD) protection	
E3	System locks up when P3 has occurred six times within 3 hours.	Cannot restart *1
P4	Compressor discharge temperature (TD) sensor error	
P5	Inverter module temperature (TF) protection	
E5	System locks up when P5 has occurred six times within 3 hours.	Cannot restart *1
P6	Compressor over-current protection	
E6	System locks up when P6 has occurred six times within 3 hours.	Cannot restart *1
P7	Liquid slugging protection	
E7	System locks up when P7 has occurred three times within 5 hours.	Cannot restart *1
P8	Low compressor voltage protection	
E8	System locks up when P8 has occurred three times within an hour.	Cannot restart *1
P9	Incorrect compressor line sequence	Cannot restart *1
PA	DC fan motor over-load protection	Cannot restart *1
F1	Ambient temperature (TA) sensor fault	Backup running*2
F2	Compressor suction temperature (TS) sensor fault	Backup running*2
F3	Liquid line temperature (TL) sensor fault	Backup running*2
F4	Defrost temperature (TH) sensor fault	Backup running*2
F5	Compressor discharge temperature (TD) sensor fault	Backup running*2
F6	Inverter module temperature (TF) sensor fault	Backup running*2
F7	High pressure (HP) sensor fault	Backup running*2
F8	Low pressure (LP) sensor fault	Backup running*2
E4	Communication fault between main chip and INV drive chip	Cannot restart *1
H0	Heavy undercharge limit operation	
H1	Ambient temperature limit operation in cooling	
H2	Ambient temperature limit operation in heating	
H3	Abnormal switch alarm for reversing valve	Alarm
H4	Defrost temperature (TH) sensor error	
H5	EEPROM fault	
H6	Low voltage alarm	
HF	Abnormal function control	Alarm
H8	Indoor refrigerant leakage alarm	
C0-CC	Compressor INV module protection	
E0	System locks up when C0~CA has occurred three times within an hour.	Cannot restart *1

Remarks:

1. Disconnect power supply switch for 5 minutes to reset, then turn on power supply for the unit.
2. Unit goes to backup running under sensors fault varies from 7 to 120 days. Allow up to two (2) sensors backup running at the same time.

16. Wiring Diagram

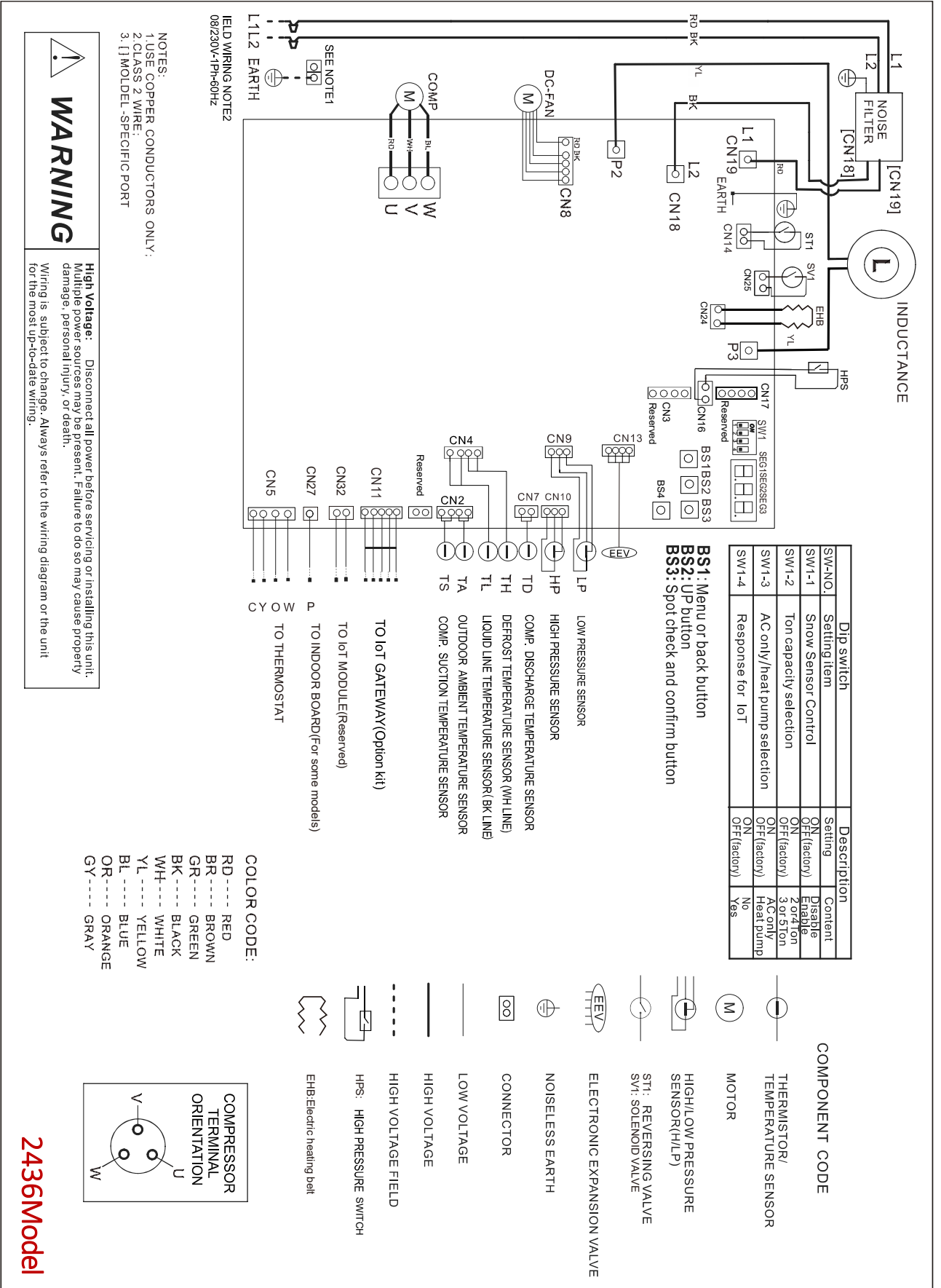

WARNING

High Voltage: Disconnect all power before servicing or installing this unit. Multiple power sources may be present. Failure to do so may cause property damage, personal injury, or death.
Wiring is subject to change. Always refer to the wiring diagram of the unit for the most up-to-date wiring.

2436Model

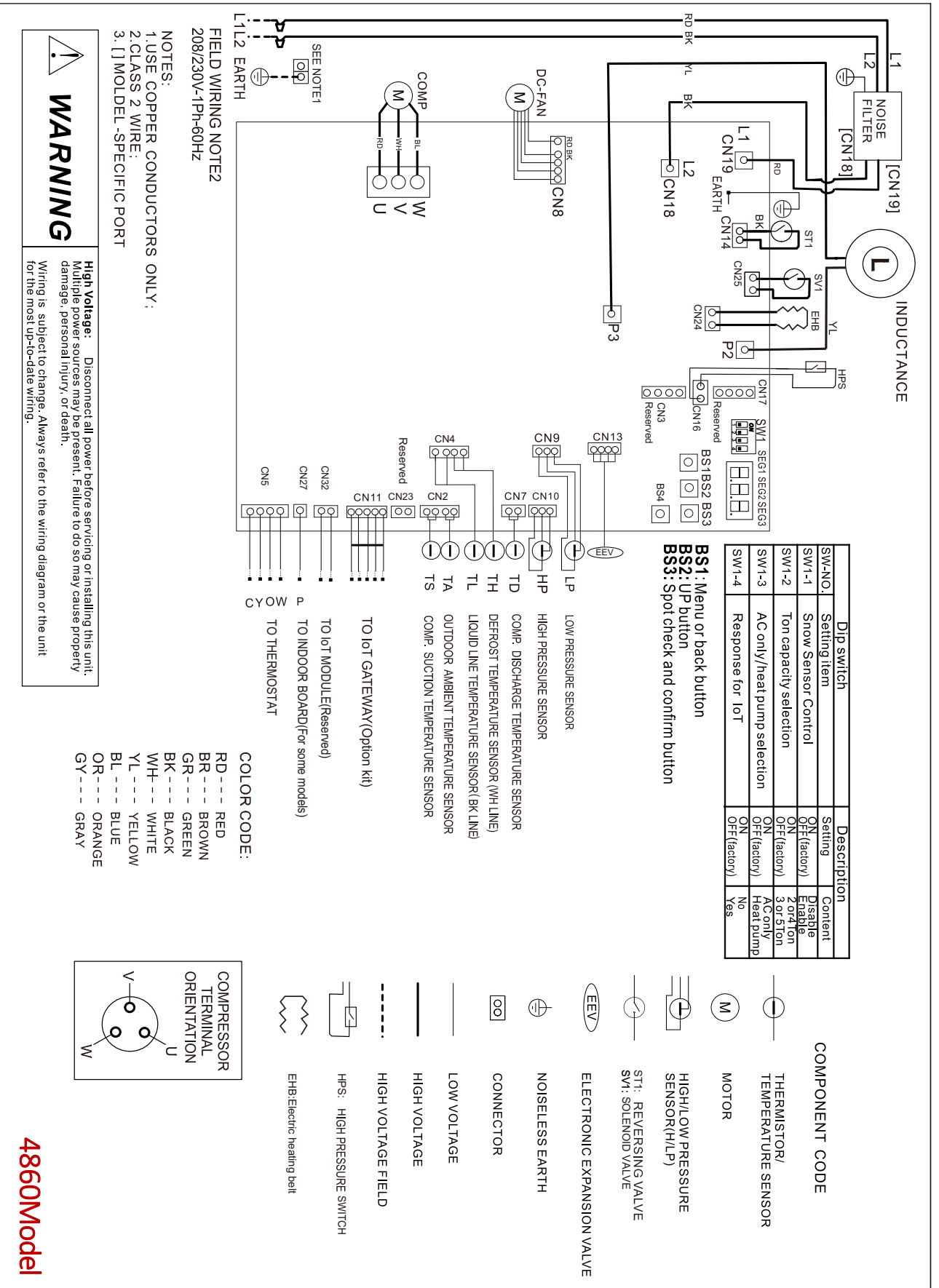

WARNING

High Voltage: Disconnect all power before servicing or installing this unit. Multiple power sources may be present. Failure to do so may cause property damage, personal injury, or death.

Wiring is subject to change. Always refer to the wiring diagram or the unit for the most up-to-date wiring.

4860Model

©2022 ECOER INC.

4040 McDermott Road, Suite 200
Plano, Texas 75024

Tel: 703-348-2538

www.ecoer.com