



Making your home Green & Smart

Installation Manual

High Efficiency Air Handlers
2-5Ton Capacity
R-454B /R32 EEV Inside

Contents

- 1. Safety Instructions----- 2
- 2. Dimensions----- 13
- 3. Applications----- 16
- 4. Electrical Wiring----- 23
- 5. Indoor Blower control function ----- 32
- 6. Airflow Performance----- 35
- 7. Ductwork----- 36
- 8. Pipe Connections----- 37
- 9. Air Filter----- 41

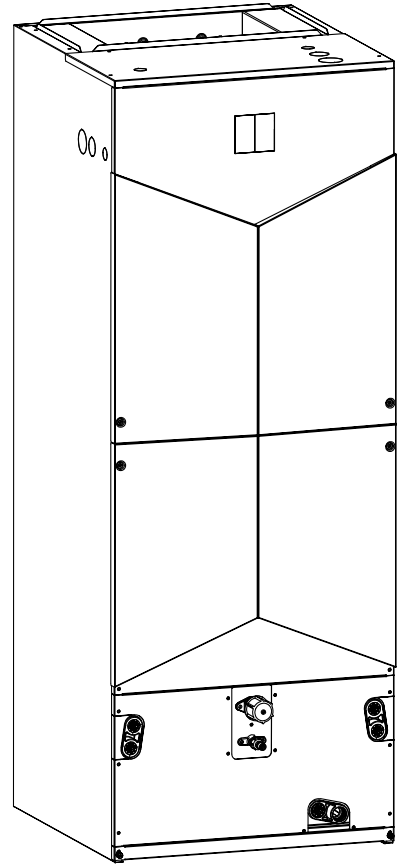

NOTE: Appearance of unit may vary. Installation must be performed in accordance with the requirements of NEC and CEC by authorized personnel only.

All phases of this installation must comply with National, State and Local Codes.

This document is customer’s property and is to remain with this unit. Please return it to customer with service information upon completion of work.

These instructions are intended as an assist to qualified and licensed personnel for proper installation, adjustment and operation of ECM air handler units. Read it thoroughly before attempting installation or service work. **Failure to follow these instructions may result in fire, electrical shock, property damage, personal injury or death.**

The instructions do not cover all variations in systems or provide for every possible contingency to be met in connection with the installation.



1. Safety Instructions

1.1 Safety

Read the following safety instructions before installing the unit or doing service work.

 **WARNING** may cause personal death or serious injury.

 **CAUTION** may lead to injury or structural damage under some conditions.



WARNING

Disconnect all power to unit before installing or servicing. More than one disconnecting switch may be required to de-energize the equipment. Hazardous voltage can cause severe personal injury or death.

Installation and maintenance must be performed by authorized personnel only.
Consumer service is recommended only for filter cleaning/replacement. Never operate the unit with the access panels removed.

Failure to inspect pipes or use proper service tools may result in equipment damage or personal injury. If using existing refrigerant pipes, make sure that all joints are brazed, not soldered.

The unit must be permanently grounded.
Failure to do so can result in electrical shock causing personal injury or death.

PROPOSITION 65: This appliance contains fiberglass insulation. Respirable particles of fiberglass are known to the State of California to cause cancer. All manufacturer products have to meet current federal OSHA Guidelines for safety.

California Proposition 65 warnings are required for certain products that are not covered by the OSHA standards. It requires warnings for products sold in California that contain or produce any of over 600 listed chemicals known to the State of California to cause cancer or birth defects such as fiberglass insulation, lead in brass, and combustion products from natural gas.

All “new equipment” shipped for sale in California will have labels stating that the product contains and /or produces Proposition 65 chemicals. Although we have not changed our processes, having the same label on all our produced facilitates manufacturing and shipping. We cannot always know “when or if” products will be sold in the California market. You may receive inquiries from customers about chemicals found in, or produced by, some of our heating and air-conditioning equipment, or found in natural gas used with some of our products. Listed below are those chemicals and substances commonly associated with similar equipment in our industry and other manufacturers.

- Glass Wool (Fiberglass) Insulation
- Carbon Monoxide (CO).
- Formaldehyde
- Benzene

More details are available at the websites for OSHA (Occupational Safety and Health Administration), at www.osha.gov and the State of California’s OEHHA (Office of Environmental Health Hazard Assessment) at www.oehha.org. Consumer education is important since the chemicals and substances on the list are found in our daily lives. Most consumers are aware that products present safety and health risks, when improperly used, handled and maintained.

WARNING

If removal of the blower assembly is required, all switches supplying power to the equipment must be disconnected and locked so the field power wires can be safely removed from the blower assembly. Failure to do so can cause electrical shock resulting in personal injuring or death.

Make sure the blower motor support is tight (3-motor mount bolts), then check if the wheel is secure to motor shaft before operating unit.

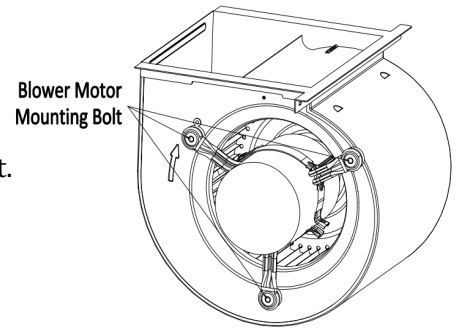

The first 6 inches of supply air plenum and ductwork must be constructed of sheet metal as required by NFPA 90B. The supply air plenum or duct must have a solid sheet metal bottom directly after the air handler unit with no openings, registers or flexible air ducts located in it. If flexible supply air ducts are used, they may be located only in the vertical walls of rectangular plenum, a minimum of 6 inches from the solid bottom. Metal plenum or duct may be connected to the combustible floor base, if not, it must be connected to the unit supply duct exposed to the supply air opening from the down-flow unit. Exposing combustible (non-metal) material to the supply opening of a down-flow unit may cause a fire resulting in property damage, personal injury or death.

Personal injury, product damage!

This information is intended for use by individuals possessing adequate backgrounds of electrical and mechanical experience. Any attempt to repair a central air conditioning product may result in personal injury and/or property damage.

Hazardous voltage!

Failure to follow this warning could result in property damage, severe personal injury, or death. Disconnect all electric power, Including remote disconnects before servicing. Follow proper lockout/tagout procedures to ensure the power cannot be inadvertently energized.

Grounding required!

Failure to inspect or use proper service tools may result in equipment damage or personal injury. Reconnect all grounding devices. All parts of this product that are capable of conducting electrical current are grounded. If grounding wires, screws, straps, clips, nuts, or washers used to complete a path to ground are removed for service, they must be returned to their original position and properly fastened.



WARNING

Brazing required!

Failure to inspect lines or use proper service tools may result in equipment damage or personal injury. If using existing refrigerant lines make certain that all joints are brazed, not soldered. If refrigerant gas leaks during installation, ventilate the area immediately. Comply with national gas regulations.

High current leakage!

Grounding is required before connecting electrical supply. Failure to follow this warning could result in property damage, severe personal injury, or death.

Risk of fire!

Flammable refrigerant used. To be repaired only by trained service personnel. Do not puncture refrigerant tubing. Dispose of properly in accordance with federal or local regulations. Flammable refrigerant used. Flammable refrigerant used. Consult repair manual/owner's guide before attempting to service this product. All safety precautions must be followed. Auxiliary devices which may be ignition sources shall not be installed in the ductwork, other than auxiliary devices listed for use with the specific appliance. See instructions.

Fire, explosion!

Store in a well ventilated room without continuously operating flames or other potential ignition.

Risk of electric shock!

Can cause injury or death. Disconnect all remote electric power supplies before servicing.

Personal injury!

This appliance is not intended for use by persons (including children) with reduced physical, sensory or mental capabilities, or persons who lack experience and knowledge, unless they are supervised or have been given instructions concerning the use of the appliance by a person responsible for their safety. Children should be supervised to ensure that they do not play with the appliance.

Any person who is involved with working on or opening a refrigerant circuit should hold a current valid certificate from an industry-accredited assessment authority, which authorizes their competence to handle refrigerants safely in accordance with an industry recognized assessment credential.

Servicing shall only be performed as recommended by the equipment manufacturer.

Maintenance and repair requiring the assistance of other skilled personnel shall be carried out under the supervision of a person competent in the use of flammable refrigerants.

Prior to beginning work on systems containing flammable refrigerants, safety checks are necessary to minimize the risk of ignition.

 **WARNING****Flammable refrigerant!**

Do not use means to accelerate the defrosting process or to clean, other than those recommended by the manufacturer.

The appliance shall be stored in a room that does not have continuously operating ignition sources (for example: open flames, an operating gas appliance or an operating electric heater).

Do not pierce or burn the unit.

Be aware that refrigerants may not contain an odour.

Safe handling of flammable refrigerant!

Be sure the air conditioner is grounded. In order to avoid electric shock, make sure that the unit is grounded and that the earth wire is not connected to a gas or water pipe, lightning conductor or telephone earth wire.

Do not operate the air conditioner with a wet hands. An electric shock may happen.

Do not operate the air conditioner when using a room fumigation - type insecticide. Failure to observe this precaution could cause the chemicals to become deposited in the unit, which could endanger the health of those who are hypersensitive to chemicals.

To avoid oxygen deficiency, ventilate the room sufficiently if equipment with a burner is used together with the air conditioner.

Arrange the drain hose to ensure smooth drainage. Incomplete drainage may cause wetting of the building, furniture, etc.

Never touch the internal parts of the controller. Do not remove the front panel. Some parts inside are dangerous to touch, and machine troubles may occur.

Attention is drawn to the fact that additional transportation regulations may exist with respect to equipment containing flammable gas. The maximum number of pieces of equipment or the configuration of the equipment permitted to be transported together will be determined by the applicable transport regulations.

Signs for similar appliances used in a work area are generally addressed by local regulations and give the minimum requirements for the provision of safety and/or health signs for a work location.

Storage package protection should be constructed such a way that mechanical damage to the equipment inside the package will not cause a leak of the REFRIGERANT CHARGE.

The maximum number of pieces of equipment permitted to be stored together will be determined by local regulations.

Do not place appliances which produce open flame in places exposed to the air flow from the unit or under the indoor unit. It may cause incomplete combustion or deformation of the unit due to the heat.

Do not install the air conditioner in a location where flammable gas may leak out. If the gas leaks out and stays around the air conditioner, a fire may break out.

 **WARNING****Flammable refrigerant!**

The appliance can use R454B/R32 refrigerant.

**Personal Injury, flammable refrigerant!**

When repairing the refrigerating system, comply with the following precautions prior to conducting work on the system:

- Work shall be undertaken according to controlled procedures to minimize the risk of the presence of flammable gases or vapors while the work is being performed.
- All maintenance staff and others working in the local area shall be instructed on the nature of work being carried out. Work in confined spaces shall be avoided.
- The area shall be checked with an appropriate refrigerant detector prior to and during work, to ensure the technician is aware of potentially toxic or flammable environment. Ensure that the leak detection equipment being used is suitable for use with all applicable refrigerants, i.e., non-sparking, adequately sealed or intrinsically safe.
- If any hot work is to be conducted on the refrigerating equipment or any associated parts, appropriate fire extinguishing equipment shall be available and easily accessible. Have a dry powder or CO2 fire extinguisher adjacent to the charging area.
- When carrying out work in relation to a refrigerating system that involves exposing any pipe work, no sources of ignition shall be used in such a manner that it may lead to the risk of fire or explosion. All possible ignition sources, including cigarette smoking, should be kept sufficiently far away from the site of installation, repair, or removal and disposal of the unit, during which refrigerant can possibly be released into the surrounding space. Prior to beginning work, the area around the equipment is to be surveyed to make sure that there are no flammable hazards or ignition risks. “No Smoking” signs shall be clearly displayed.

Personal Injury, flammable refrigerant!

Refrigerating pipe or components are installed in a position where they are unlikely to be exposed to any substances which may corrode refrigerant containing components, unless the components are constructed of materials that are inherently resistant to corrosion or are suitably protected against corrosion.

Repair and maintenance of electrical components shall include initial safety checks and component inspection procedures. If a fault exists that could compromise safety, then no electrical supply shall be connected to the circuit until the fault has been dealt with.

- That capacitors are discharged: this shall be done in a safe manner to avoid the possibility of sparking.
- That no live electrical components and wiring are exposed while charging, recovering or purging the system.
- That there is continuity of grounding.

 **WARNING****Personal Injury, flammable refrigerant!**

Ensure that the area is in the open or that it is adequately ventilated before opening the system or conducting any hot work. A degree of ventilation shall continue during the period that the work is carried out. The ventilation should safely disperse any released refrigerant and preferably expel it externally into the surroundings.

Where electrical components are being changed, they shall be fit according to their purpose and to the correct specification. At all times the manufacturer's maintenance and service guidelines shall be followed. If in doubt, consult the manufacturer's technical department for assistance. The following checks shall be applied to installations using flammable refrigerants:

- The actual refrigerant charge is in accordance with the room size within which the refrigerant containing parts are installed.
- The ventilation machinery and outlets are operating adequately and are not obstructed.
- If an indirect refrigerating circuit is being used, the secondary circuit shall be checked for the presence of refrigerant.
- Equipment marking must remain visible and legible. Markings and signs that are illegible shall be corrected.

Flammable refrigerant!

Sealed electrical components shall be replaced.

Intrinsically safe components must be replaced.

Check that cabling will not be subject to wear, corrosion, excessive pressure, vibration, sharp edges or any other adverse environmental effects. The check shall also take into account the effects of aging or continual vibration from sources such as compressors or fans.

Under no circumstances shall potential sources of ignition be used while searching for or detection of refrigerant leaks. A halide torch (or any other detector using a naked flame) shall not be used.

Electronic leak detectors may be used to detect refrigerant leaks but, in the case of flammable refrigerants, the sensitivity may not be adequate, or may need recalibration. (Detection equipment shall be calibrated in a refrigerant-free area.)

Ensure that the detector is not a potential source of ignition and is suitable for the refrigerant used. Leak detection equipment shall be set at a percentage of the LFL of the refrigerant and shall be calibrated for the refrigerant employed, and the appropriate percentage of gas (25 % maximum) is confirmed. If a leak is suspected, all naked flames shall be removed/extinguished.

If a leakage of refrigerant which requires brazing is found, all of the refrigerant shall be recovered from the system, or isolated (by means of shut off valves) in a part of the system remote from the leak.

Leak detection fluids are also suitable for use with most refrigerants but the use of detergents containing chlorine shall be avoided as the chlorine may react with the refrigerant and corrode the copper pipe-work.

Examples of leak detection fluids are:

- bubble method,
- fluorescent method agents.

 **WARNING****Flammable refrigerant!**

When breaking into the refrigerant circuit to make repairs or for any other purpose conventional procedures shall be used. However, for flammable refrigerants it is important that best practice be followed, since flammability is a consideration. The following procedure shall be adhered to:

- safely remove refrigerant following local and national regulations.
- evacuate.
- purge the circuit with inert gas.
- evacuate.
- continuously flush or purge with inert gas when using flame to open circuit, and.
- open the circuit.

The refrigerant charge shall be recovered into the correct recovery cylinders if venting is not allowed by local and national codes. For appliances containing flammable refrigerants, the system shall be purged with oxygen-free nitrogen to render the appliance safe for flammable refrigerants. This process might need to be repeated several times. Compressed air or oxygen shall not be used for purging refrigerant systems.

For appliances containing flammable refrigerants, refrigerants purging shall be achieved by breaking the vacuum in the system with oxygen-free nitrogen and continuing to fill until the working pressure is achieved, then venting to atmosphere, and finally pulling down to a vacuum. This process shall be repeated until no refrigerant is within the system. When the final oxygen-free nitrogen charge is used, the system shall be vented down to atmospheric pressure to enable work to take place.

The outlet for the vacuum pump shall not be close to any potential ignition sources, and ventilation shall be available.

Ensure that contamination of different refrigerants does not occur when using charging equipment.

Hoses or lines shall be as short as possible to minimize the amount of refrigerant they contain.

Cylinders shall be kept upright. Ensure that the refrigeration system is grounded prior to charging the system with refrigerant.

Label the system when charging is complete (if it is not already labeled).

Take extreme care not to overfill the refrigeration system.

Product damage, personal injury!

This outdoor unit must combine the indoor unit with refrigerant leak detection device.

These instructions are exclusively intended for qualified contractors and authorized installers. Work on the refrigerant circuit with mild flammable refrigerant in safety group A2L may only be carried out by authorized heating contractors.

These heating contractors must be trained in accordance with UL 60335-2-40, Section HH. The certificate of competence from an industry accredited body is required.

Work on electrical equipment may only be carried out by a qualified electrician.

Before initial commissioning, all safety – related points must be checked by the particular certified heating contractors. The system must be commissioned by the system installer or a qualified person authorized by the installer.

 **WARNING****Flammable refrigerant!**

Prior to recharging the system, it shall be pressure-tested with the appropriate purging gas. The system shall be leak-tested on completion of charging but prior to commissioning. A follow up leak test shall be carried out prior to leaving the site.

Before carrying out this procedure, it is essential that the technician is completely familiar with the equipment and all its detail. It is recommended that all refrigerants are recovered safely. Prior to the task being carried out, an oil and refrigerant sample shall be taken in case analysis is required prior to re-use of reclaimed refrigerant. It is essential that electrical power is available before the task is commenced.

- a. Become familiar with the equipment and its operation.
- b. Isolate system electrically.
- c. Before attempting the procedure ensure that:
 - mechanical handling equipment is available, if required, for handling refrigerant cylinders.
 - all personal protective equipment is available and being used correctly.
 - the recovery process is supervised at all times by a competent person.
 - recovery equipment and cylinders conform to the appropriate standards.
- d. Pump down refrigerant system, if possible.
- e. If a vacuum is not possible, make a manifold so that refrigerant can be removed from various parts of the system.
- f. Make sure that the cylinder is situated on the scales before recovery takes place.
- g. Start the recovery machine and operate it in accordance with the manufacturer's instructions.
- h. Do not overfill cylinders. (No more than 80% volume liquid charge).
- i. Do not exceed the maximum working pressure of the cylinder, even temporarily.
- j. When the cylinders have been filled correctly and the process has been completed, make sure that the cylinders and the equipment are removed from site promptly and all isolation valves on the equipment are closed off.
- k. Recovered refrigerant shall not be charged into another refrigeration system unless it has been cleaned and checked.

Equipment shall be labeled stating that it has been de-commissioned and emptied of refrigerant. The label shall be dated and signed. Ensure that there are labels on the equipment stating the equipment contains flammable refrigerant.

When removing refrigerant from a system, either for servicing or decommissioning, it is recommended that all refrigerants are removed safely.

When transferring refrigerant into cylinders, ensure that only appropriate refrigerant recovery cylinders are employed. Ensure that the correct number of cylinders for holding the total system charge is available. All cylinders to be used are designated for the recovered refrigerant and labelled for that refrigerant (i.e. special cylinders for the recovery of refrigerant). Cylinders shall be complete with pressure-relief valve and associated shut-off valves in good working order. Empty recovery cylinders are evacuated and, if possible, cooled before recovery occurs.

 **WARNING****Flammable refrigerant!**

The recovery equipment shall be in good working order with a set of instructions concerning the equipment that is at hand and shall be suitable for the recovery of the flammable refrigerant. If in doubt, the manufacturer should be consulted. In addition, a set of calibrated weighing scales shall be available and in good working order. Hoses shall be complete with leak-free disconnect couplings and in good condition.

The recovered refrigerant shall be processed according to local legislation in the correct recovery cylinder, and the relevant waste transfer note arranged. Do not mix refrigerants in recovery units and especially not in cylinders.

If compressors or compressor oils are to be removed, ensure that they have been evacuated to an acceptable level to make certain that flammable refrigerant does not remain within the lubricant. The compressor body shall not be heated by an open flame or other ignition sources to accelerate this process. When oil is drained from a system, it shall be carried out safely.

Do not use the air conditioner for other purposes. In order to avoid any quality deterioration, do not use the unit for the cooling of precision instruments, food, plants, animals or works of art. Before cleaning, be sure to stop the operation, turn the breaker off or unplug the supply cord. Otherwise, electric shock and injury may occur.

To avoid electric shock or fire, make sure that a leak detector is installed. Never touch the air outlet or the horizontal blades while the swing flap is in operation. Fingers may be come caught or the unit may break down. Never put any objects into the air inlet or outlet. Objects touching the fan at high speed can be dangerous. Never inspect or service the unit by yourself. Ask a qualified service person to perform this task.

Do not dispose of this product as unsorted municipal waste. This waste should be collected separately for special treatment. Do not dispose of electrical appliances as unsorted municipal waste. Use separate collection facilities. Contact your local government for information regarding the connection systems available.

If electrical appliances are disposed of in landfills or dumps, hazardous substances can leak into the groundwater and get into the food chain, hazardous to one's health and well-being.

To prevent refrigerant leak, contact your dealer.

When the system is installed and operates in a small room, it is required to maintain the concentration of the refrigerant below the limit, in case a leak occurs. Otherwise, oxygen in the room may be affected, resulting in a serious accident.

The refrigerant in the air conditioner is safe and normally does not leak. If the refrigerant leaks into the room and encounters the fire of a burner, a heater or a cooker, a harmful gas could be released.

Turn off any combustible heating devices, ventilate the room, and contact the dealer where the unit was purchased.

Do not use the air conditioner until a service person confirms that the refrigerant leak is repaired.

Keep ventilation openings clear of obstruction

 **WARNING****Room size restriction**

The appliances are connected via an air duct system to one or more rooms, the bottom of the air outlet of the air duct in the room should be at a height $\geq 7.3\text{ft}/2.2\text{m}$ from the floor. In UL/CSA 60335-2-40, the R454B/R32 refrigerant belongs to mildly flammable refrigerants, which will limit the room area of the system service. Similarly, the total amount of refrigerant in the system should be less than or equal to the maximum allowable refrigerant charge, which depends on the room area serviced by the system.

Note: For minimum room areas at higher installation heights, see instructions (note is optional).

Installation method:

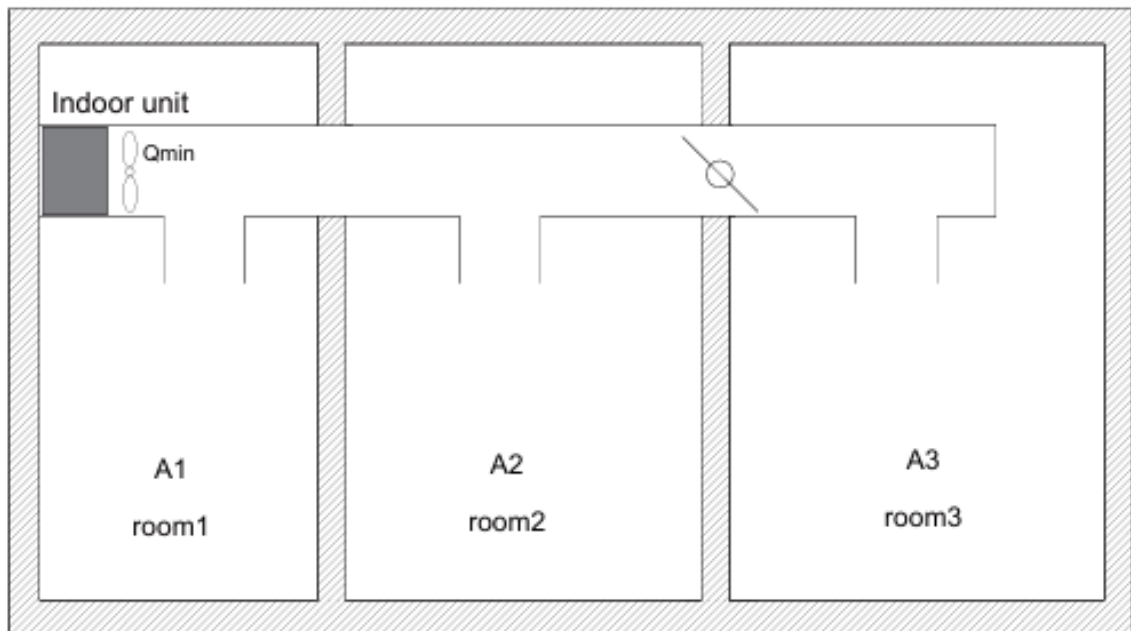

Make sure that the applied room space area T_A is larger than the T_{Amin} .

For R454B/R32 refrigerant charge amount and minimum room area:

Mc [oz/kg]	TAmin [ft²/m²]	Mc [oz/kg]	TAmin [ft²/m²]	Mc [oz/kg]	TAmin [ft²/m²]	Mc [oz/kg]	TAmin [ft²/m²]
56.5/1.6	51/4.74	134/3.8	126/11.67	211.6/6.0	198/18.43	289.2/8.2	271/25.18
63.5/1.8	60/5.53	141.1/4	132/12.29	218.7/6.2	205/19.04	296.3/8.4	278/25.8
70.5/2	66/6.14	148.1/4.2	139/12.9	225.8/6.4	212/19.66	303.4/8.6	284/26.41
77.6/2.2	73/6.76	155.2/4.4	145/13.51	232.8/6.6	218/20.27	310.4/8.8	291/27.63
84.6/2.4	79/7.37	162.2/4.6	152/14.13	239.9/6.8	225/20.88	317.5/9.0	298/27.64
91.7/2.6	86/7.99	169.3/4.8	159/14.74	246.9/7.0	231/21.5	324.5/9.2	304/28.26
98.8/2.8	93/8.6	176.4/5	165/15.36	254/7.2	238/22.11	331.6/9.4	311/28.87
105.8/3	99/9.21	183.4/5.2	172/15.97	261/7.4	245/22.73	338.6/9.6	317/29.48
112.9/3.2	106/9.83	190.5/5.4	179/16.58	268.1/7.6	251/23.34	345.7/9.8	324/30.10
119.9/3.4	112/10.44	197.5/5.6	185/17.2	275.1/7.8	258/23.96	352.7/10.0	331/30.71
127/3.6	119/11.06	204.6/5.8	192/17.81	282.2/8.0	264/24.57		

Area
formula

TA_{min} is the required minimum room area in ft² / m²
Mc is the actual refrigerant charge in the system in oz/kg
h_{inst} is the height of the bottom of the appliance relative to the floor of the room after installation.
WARNING: The minimum room area or minimum room area of conditioned space is based on releasable charge and total system refrigerant charge.
 Note: TA=A1+A2+A3+...+An (If there is a damper in the duct. When damper is open, the room area TA is the sum of all room area connected by ductwork. If it is closed, TA is the sum of the room areas before the damper.)
 Note: Calculate Mc by considering the length of pipeline connections, 0.59 oz/ft.

When the unit detects a refrigerant leak, the minimum airflow of the indoor unit is as follows:
 (The output air volume is based on the machine's full load air volume)

Model	24K	36K	48K	60K
Qmin [m ³ /h(SCFM)]	791(466)	791(466)	1136(669)	1136(669)
QminA [m ³ /h(SCFM)]	832(490)	1248(735)	1783(1050)	1953(1150)

Note: Qmin refers to the Minimum airflow of the indoor unit (see Table 5.1 for details), which is not less than QminA.

2. Dimensions

NOTE: 25" CLEARANCE IS REQUIRED IN THE FRONT OF THE UNIT FOR FILTER AND COIL MAINTENANCE.

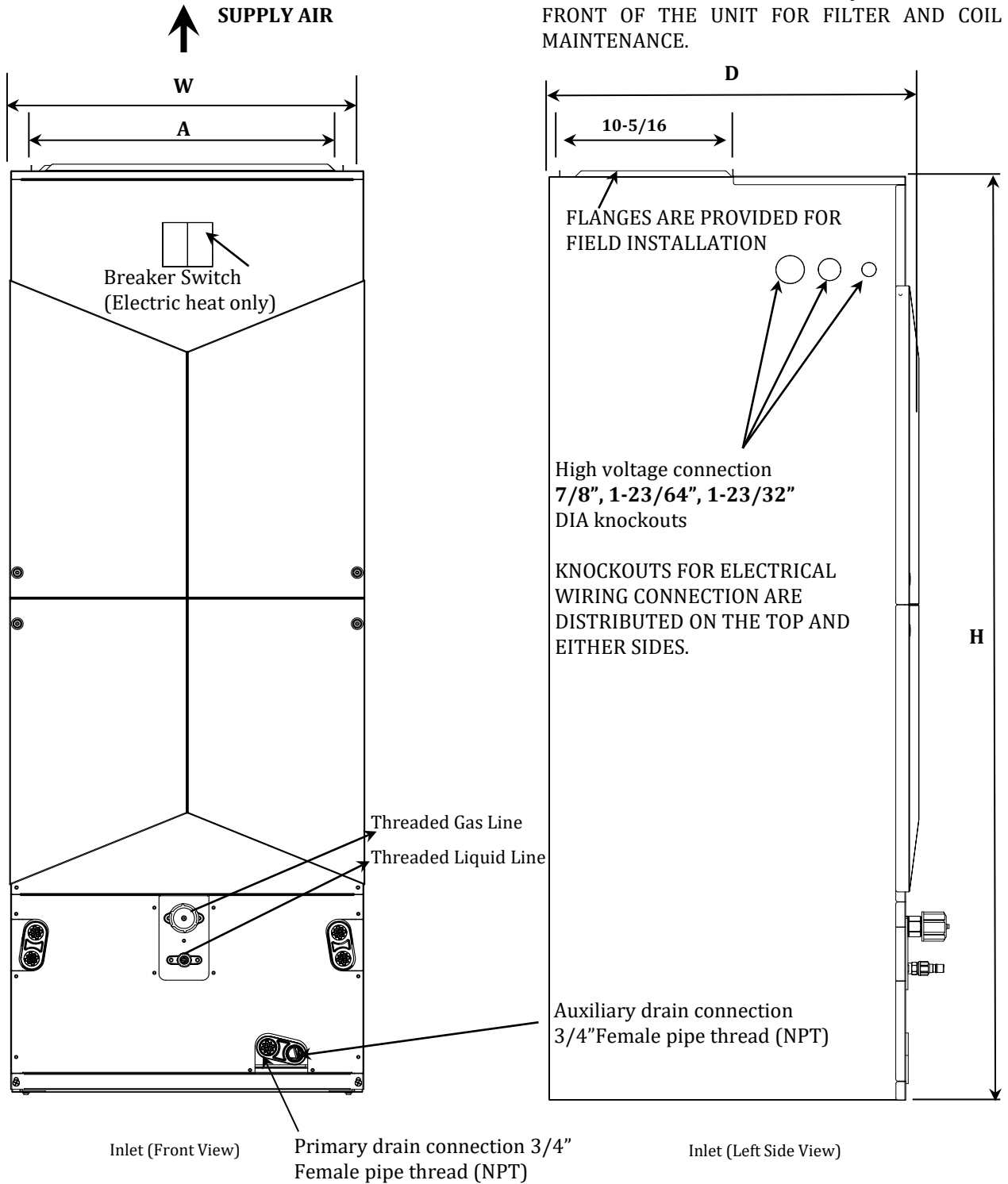
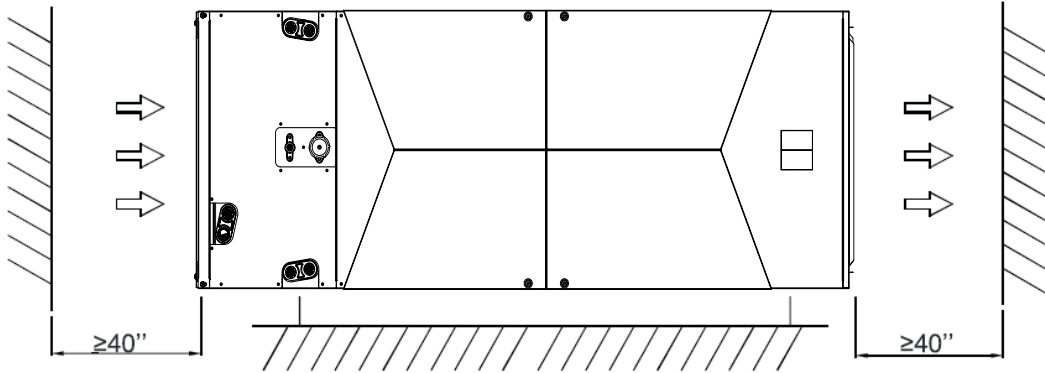

Figure 2-1 Unit Dimensions

Model	Dimensions (in.)					
	H	W	D	A	Liquid Line Connection	Gas Line Connection
24 / 36	47-11/64	21-3/16	23-37/64	19-1/4	3/8	3/4
48 / 60	56-13/16	21-3/16	23-37/64	19-1/4	3/8	7/8

Installation Position Requirements

Select a solid and level site, keep enough space for proper installation and maintenance.



a) Horizontal Position

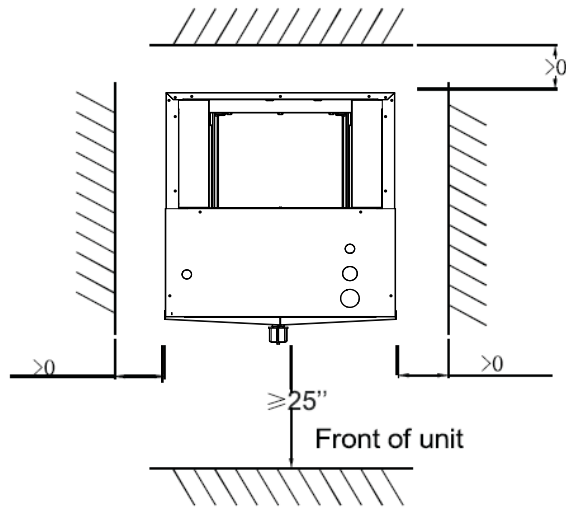

b) Vertical Position

Figure 2-2 Clearance requirement

PRODUCT OVERVIEW

IMPORTANT

Lightly tighten the drain connections so it won't leak.

Using excessive force may cause damage to the drain connections. Torque applied to drain connections should not exceed 10.ft.lbs.

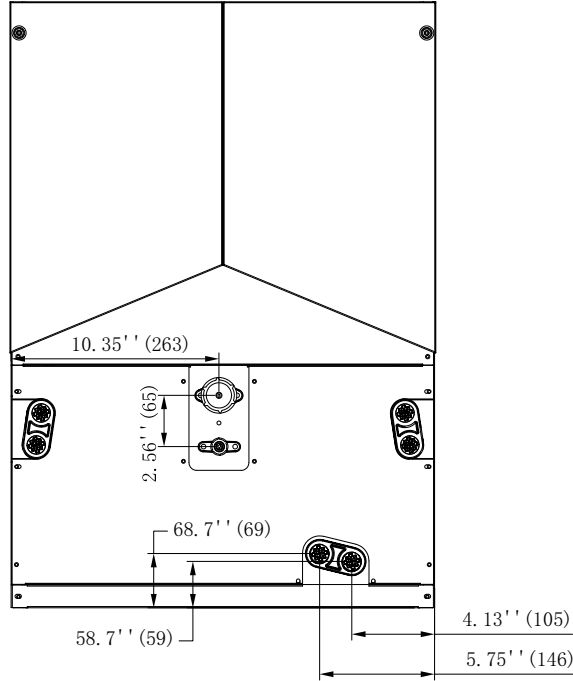

Figure 1 Dimensions for front connection coil

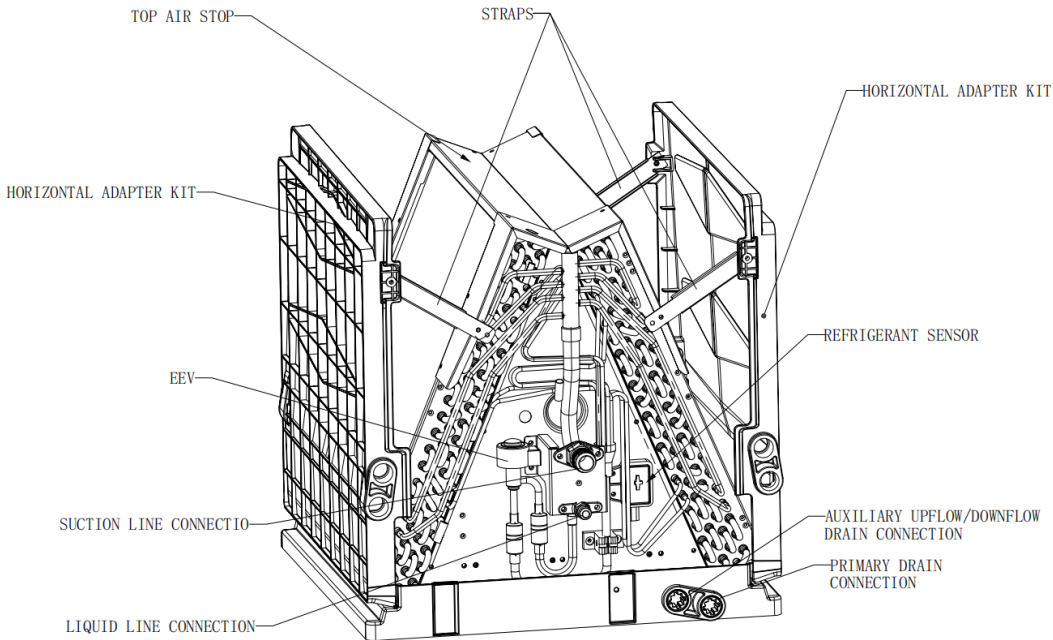
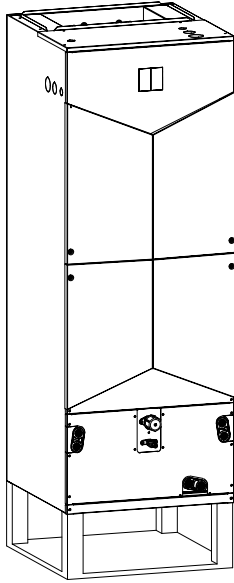

Figure 2 Indoor coil and drain pan set-up

3. Applications

3.1 Selection of installation direction

The units can be installed in a vertical (down and up) and Horizontal (right and left) configuration.



Vertical

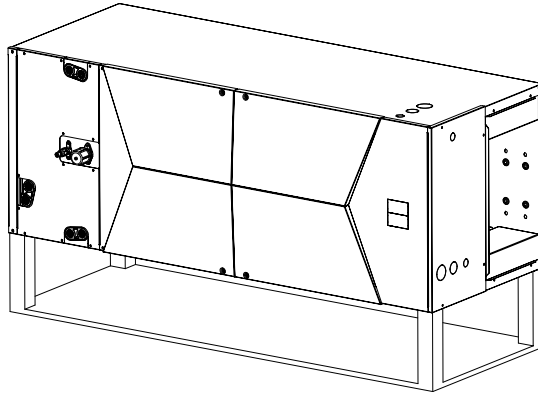

Horizontal

NOTICE

For horizontal installation, a secondary drain pan (not supplied by the manufacturer) must be installed.

Airflow direction of different installation directions

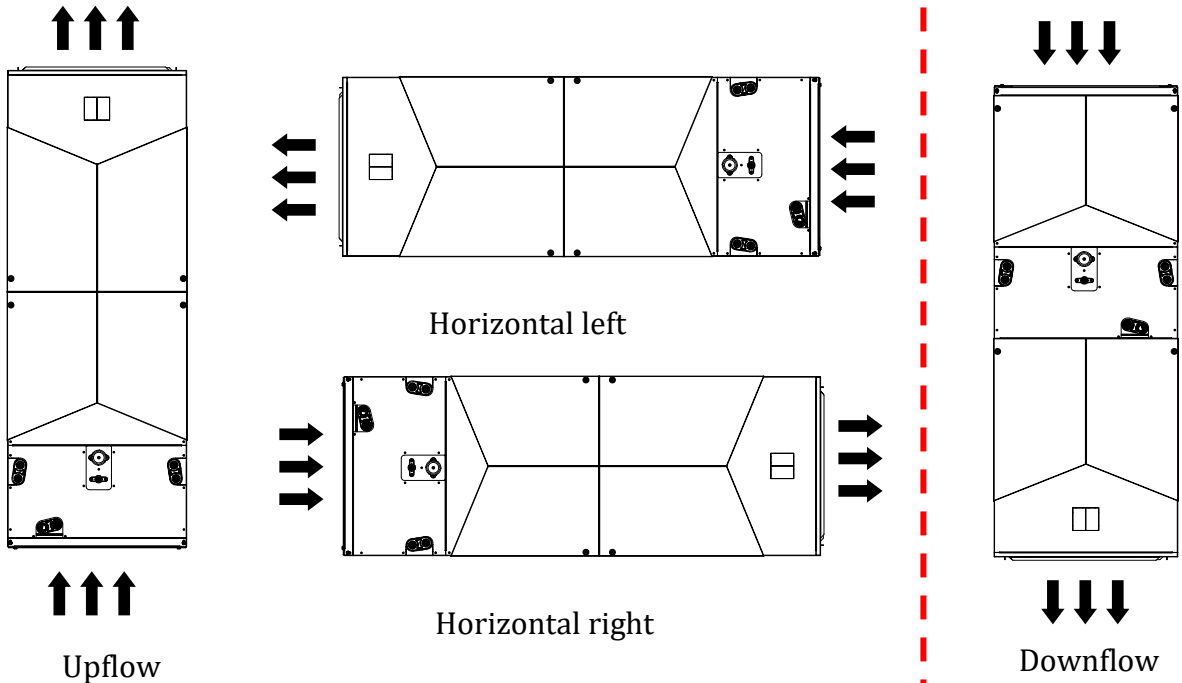

3.2 Vertical up-flow and Horizontal right-flow

Vertical up-flow and horizontal right-flow configurations are the factory settings on all models.

If return air is to be ducted, install duct flush with floor. Use fireproof resilient gasket 1/8 to 1/4 in. thick between the ducts, unit and floor. Set unit on floor over opening.

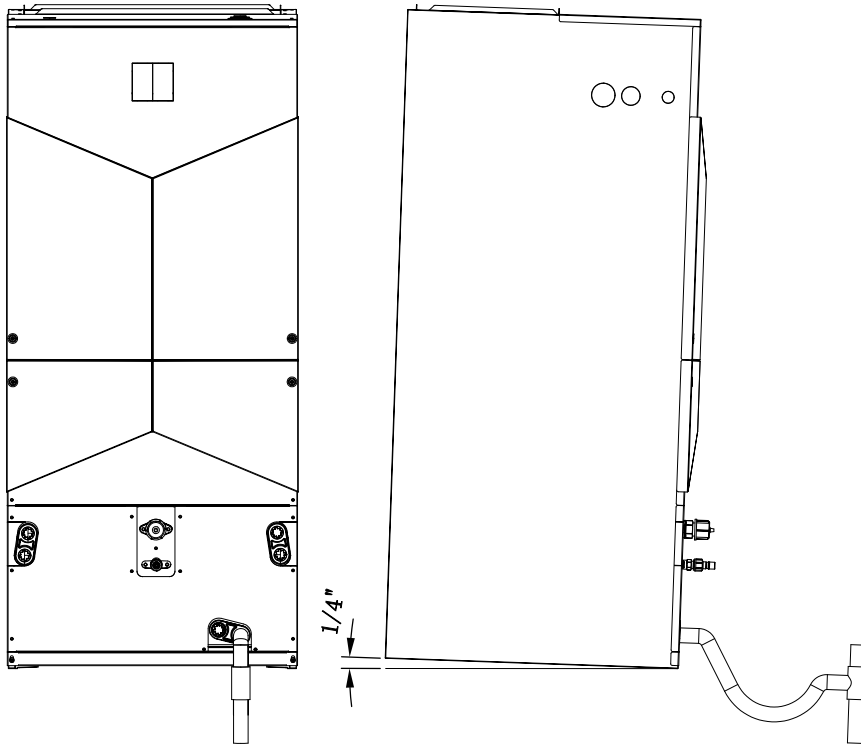

Figure 1 Vertical up view

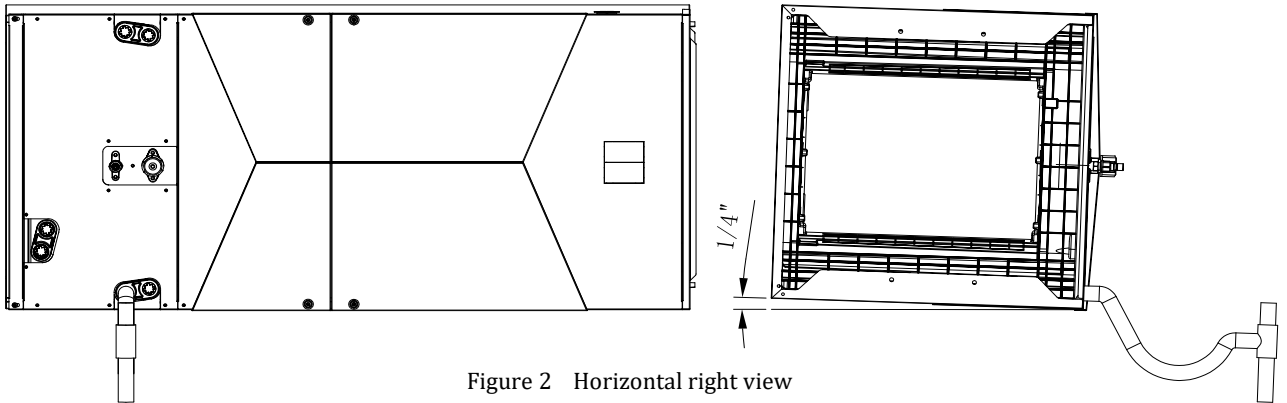

Figure 2 Horizontal right view

IMPORTANT

Make sure unit is leveled or pitched slightly toward primary drain connection so that water will drain completely from the pan. Up to an additional 1/4" rise over the width or depth of the unit is allowed to create additional sloping towards the drain. Unit must be positioned between level and 1/4" rise, sloping toward the drain connections.

CAUTION

Horizontal drain pan must be located under indoor coil. Failure to use the drain pan can result in property damage.

3.3 Horizontal left-flow

STEP 1

As shown in Figure 3-1, remove Lower panel 2 and take out the refrigerant leak sensor. Reinstall the removed screws in their original locations. Install the refrigerant leak sensor at the location shown in Fig. 3-2, and secure it with the two screws provided in the accessory bag.

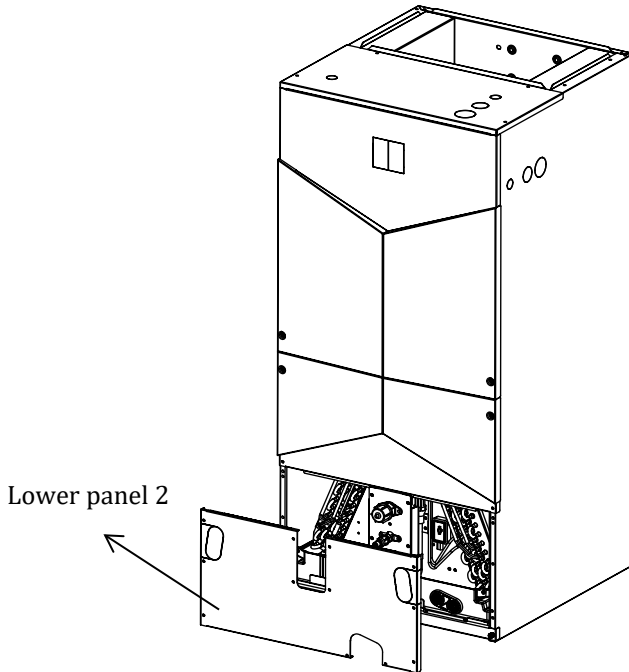

Figure 3-1

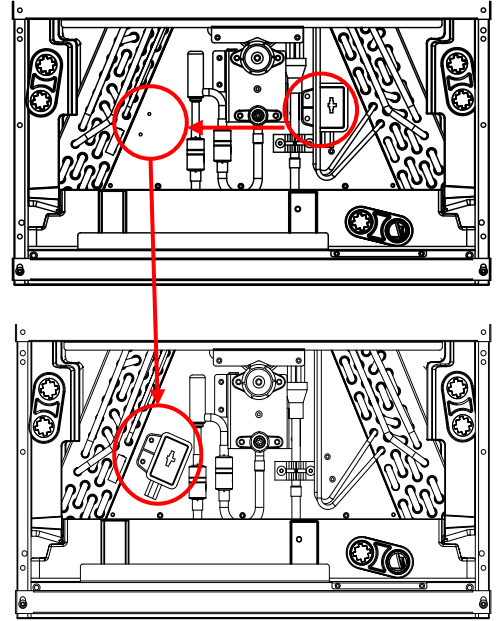

Figure 3-2

STEP 2

Reinstall Rear Panel Assembly 2 in its original position and secure it with screws. Then configure the unit for left-hand air discharge.

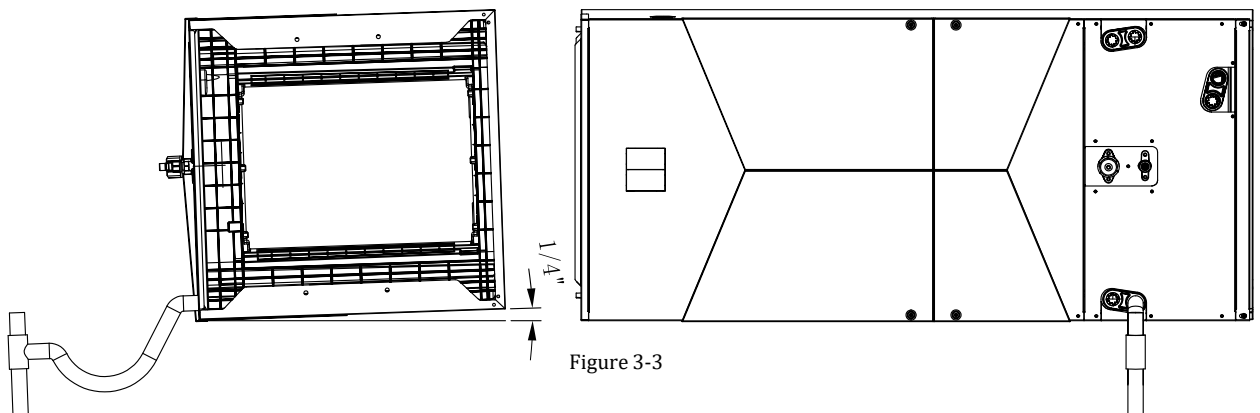

Figure 3-3

IMPORTANT

Make sure unit is leveled or pitched slightly toward primary drain connection so that water will drain completely from the pan. Up to an additional 1/4" rise over the width or depth of the unit is allowed to create additional sloping towards the drain. Unit must be positioned between level and 1/4" rise, sloping toward the drain connections.

CAUTION

Horizontal drain pan must be located under indoor coil. Failure to use the drain pan can result in property damage.

3.4 Down flow instructions

NOTICE

When installing the down follow configurations, please pay attention to the requirements for airflow settings.

STEP 1

Remove the screws from the upper and lower panels as shown in Figure 3-4.

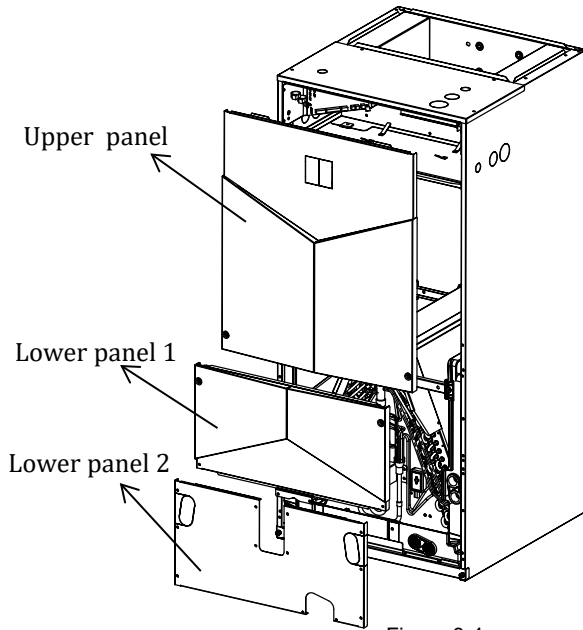

Figure 3-4

STEP 2

Remove the screws from the filter cover, support strip 2 as shown in Figure 3-5.

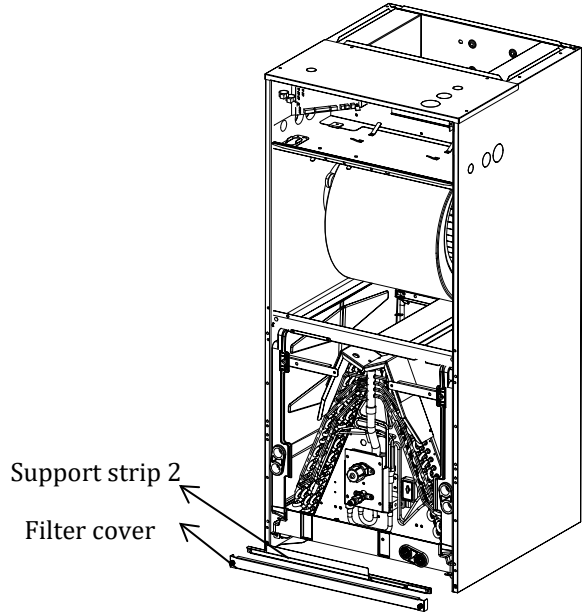

Figure 3-5

STEP 3

Disconnect the electronic expansion valve (EEV) coil (1 pc), refrigerant leak sensor (1 pc), and temperature sensors (2 pcs) from the indoor unit main control board. Route the wiring harnesses out through the cable pass-through opening in the air duct mounting plate (see Figure 3-6), then release Support Bracket No. 1 and remove the cable tie securing the wiring (see Figure 3-7).

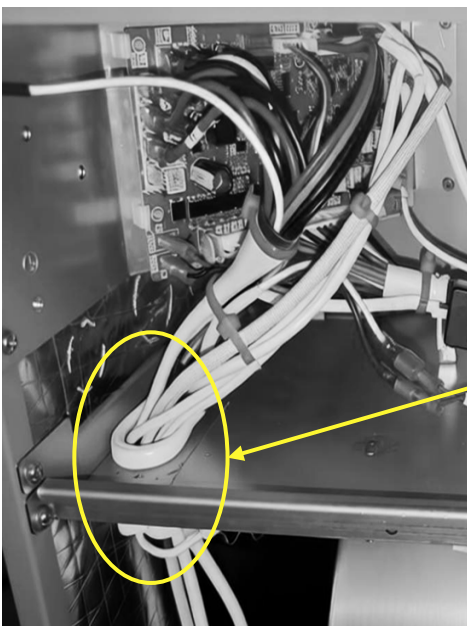

Figure 3-6

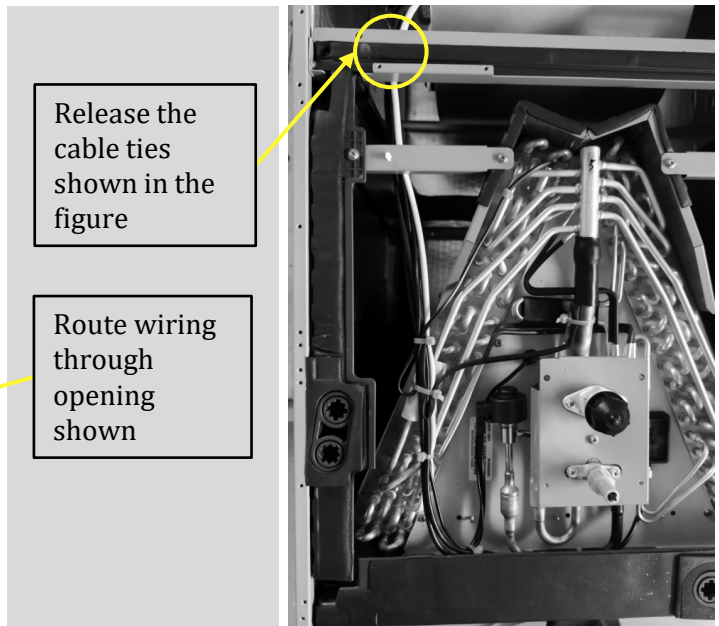

Figure 3-7

3.4 Down flow instructions

STEP 4

Remove the T1 ambient temperature sensor only, keeping all other sensor connections and wiring harness routing unchanged. Then remove the evaporator assembly from the cabinet, and open the round sheet-metal knock-out at the location shown in Figure 3-8.

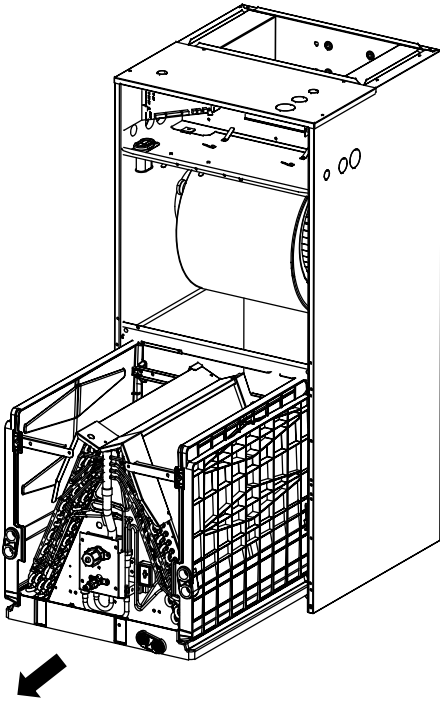

Figure 3-8

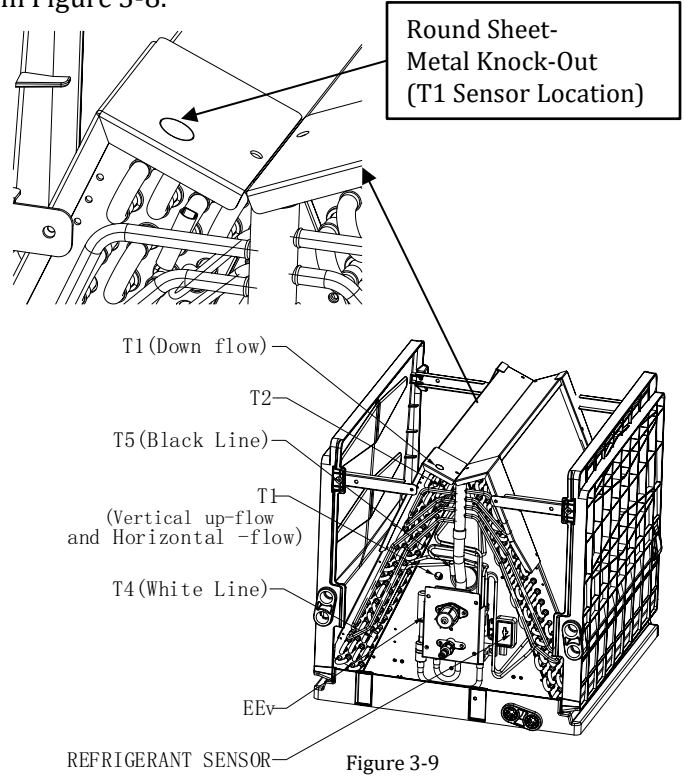

Figure 3-9

STEP 5

Rotate the outlet of cabinet to the air outlet direction. After mounting the evaporator assembly onto the middle rail. Shown in Figure 3-10.

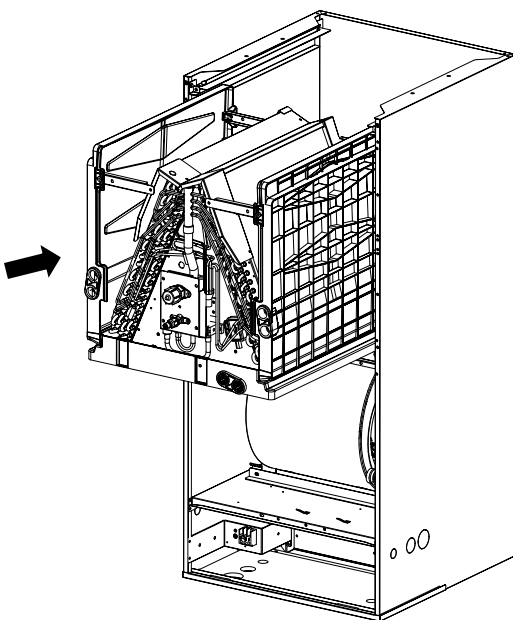

Figure 3-10

STEP 6

Secure the screws on support strips 1 and 2 and the piping cover panel separately. Shown in Figure 3-11.

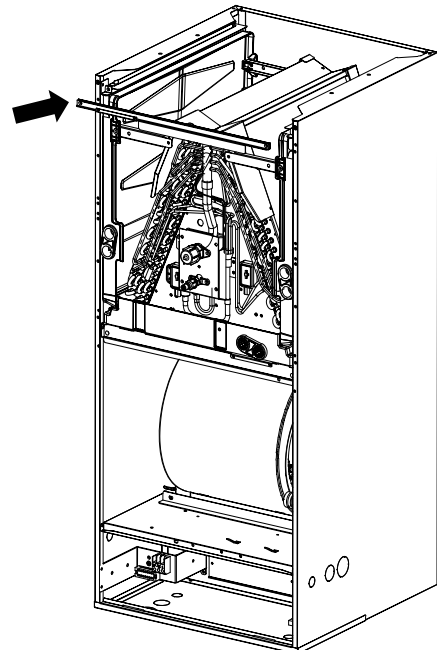

Figure 3-11

3.4 Down flow instructions

STEP 7

As shown in Figure 3-12, install the T1 ambient temperature sensor into the round sheet-metal knock-out opened in Step 4. Seal the original T1 sensor mounting hole using the foam pad supplied in the accessory bag.

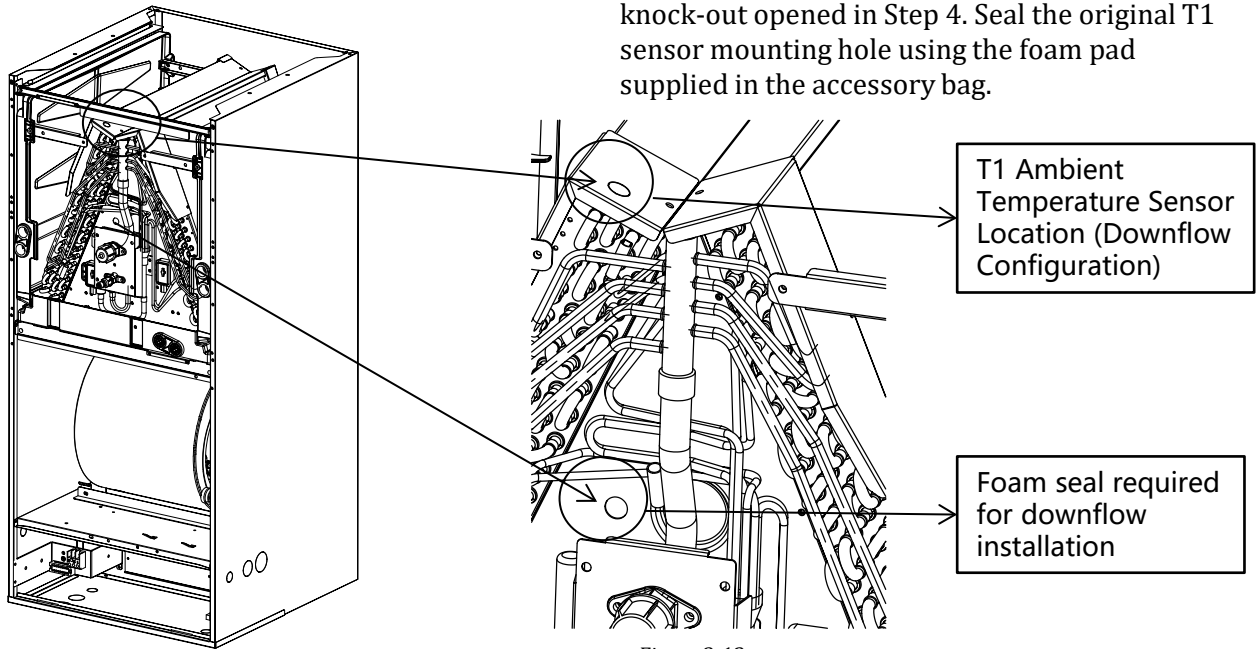
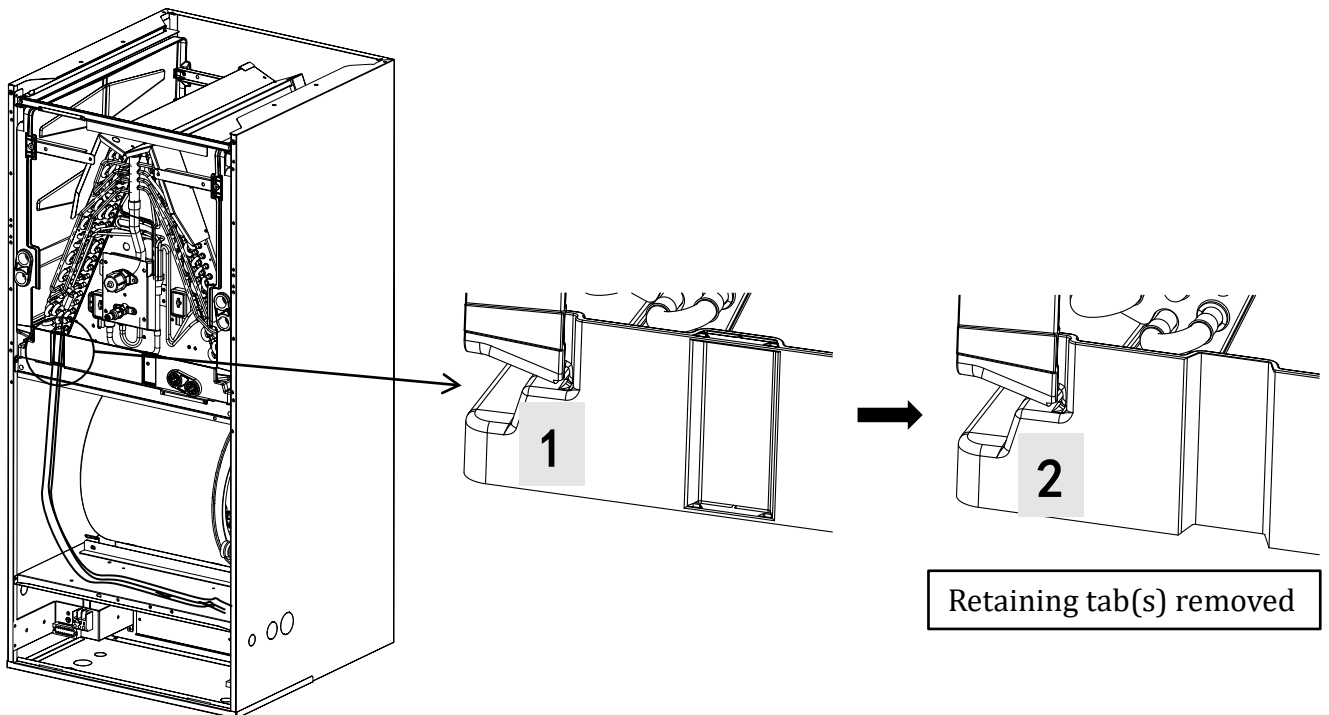

Figure 3-12

STEP 8

As shown in Figure 3-13, remove the retaining tabs on both the upper and lower sides of the groove. Route the removed wiring harness along the path indicated in the figure. After confirming that all wiring is properly seated within the designated groove, cover the wiring with the foam pad supplied in the accessory bag and secure it in place. Ensure the foam pad fully covers the condensate pan groove area to maintain proper unit sealing performance.



3.4 Down flow instructions

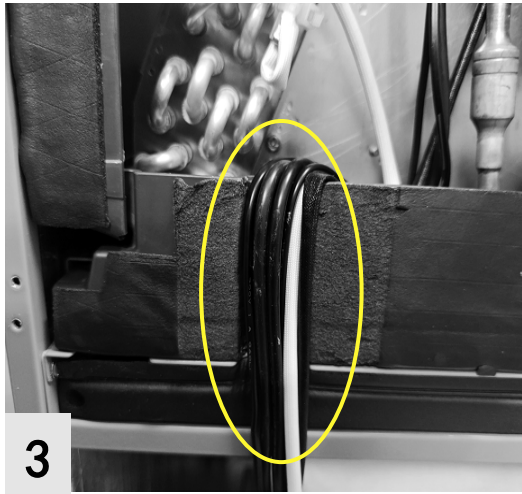

3

Place wiring flat in groove

STEP 9

Secure the screws on upper and lower panels, and install the filter, filter cover plate. Shown in Figure3- 14. As shown in Figure3-15, complete the assembly process.

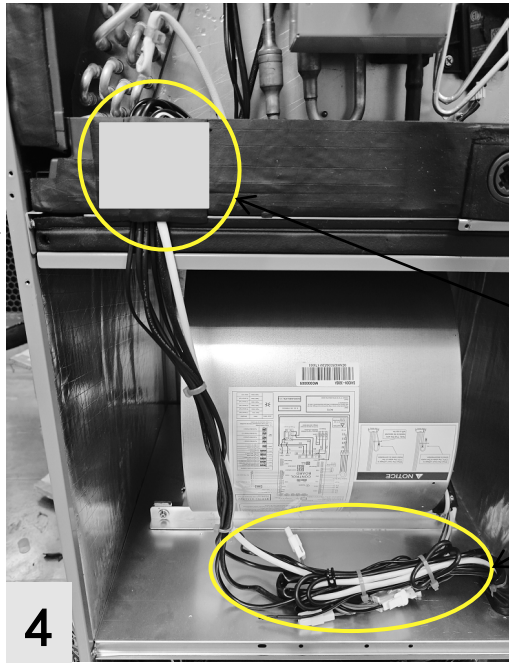

4

Apply foam pad over wiring

Secure wiring to motor lead with cable tie

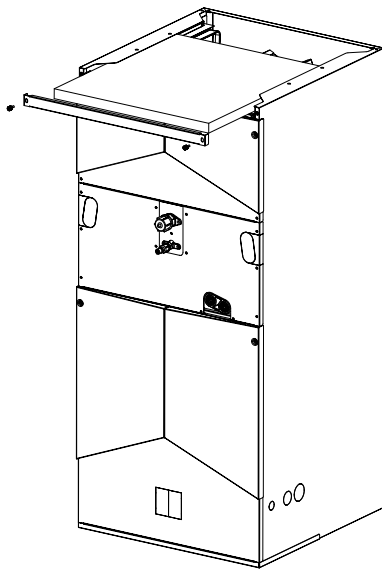

Figure 3-14

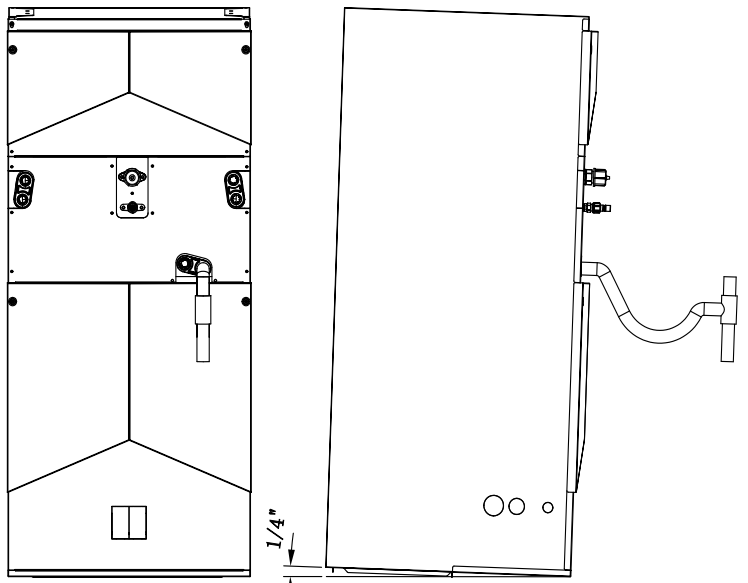

Figure 3-15

IMPORTANT

Make sure unit is leveled or pitched slightly toward primary drain connection so that water will drain completely from the pan. Up to an additional 1/4" rise over the width or depth of the unit is allowed to create additional sloping towards the drain. Unit must be positioned between level and 1/4" rise, sloping toward the drain connections.

CAUTION

Horizontal drain pan must be located under indoor coil. Failure to use the drain pan can result in property damage.

4. Electrical Wiring

Field wiring must comply with the National Electric Code (C.E.C. in Canada) and any applicable local ordinance.

WARNING

Disconnect all power to unit before installing or servicing. More than one disconnect switch may be required to de-energize the equipment. Hazardous voltage can cause severe personal injury or death.

4.1 Power Wiring

It is important that proper electrical power is available for connection to the unit model being installed. Refer to the unit nameplate, wiring diagram and electrical data in the installation instructions.

- If required, install a branch circuit disconnect of adequate size, located within sight of, and readily accessible to the unit.
- We recommend the Installation of a GFIC (install the GFIC as per your local codes).
- When the electric heat is installed, units may be equipped with one or two 30~60 amp. circuit breakers. These breakers protect the internal wiring in the event of a short circuit and serve as a disconnect. Circuit breakers installed within the unit do not provide over-current protection of the supply wiring and therefore may be sized larger than the branch circuit protection.
- Supply circuit power wiring must be 167°F minimum copper conductors only. Refer to electrical data in this section for ampacity, wire size and circuit protector requirements. Supply circuit protective devices may be either fuses or “HACR” type circuit breakers.

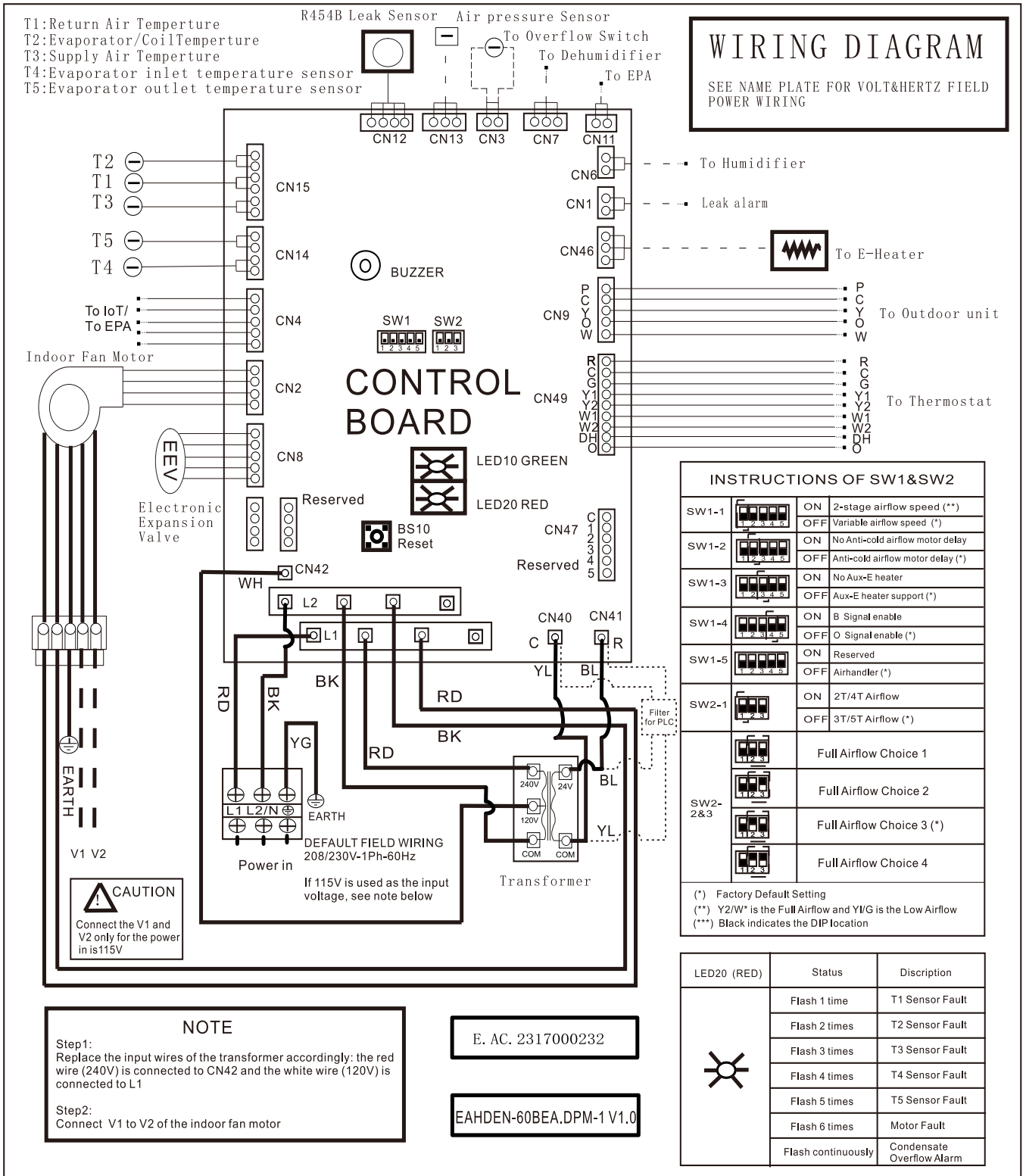

Figure 4-1 Indoor unit Wiring Diagram

4.2 Control Wiring

Class 2 low voltage control wiring should not be run in conduit with main power wiring and must be separated from power wiring, unless class 1 wire of proper voltage rating is used.

- Low voltage control wiring should be color-coded **18 AWG**. For lengths longer than 150 ft. 16 AWG. wire shall be used and maximum 225 ft.
- Refer to wiring diagrams attached to indoor and outdoor sections to be connected.
- Make sure separation of control wiring and power wiring has been maintained.

4.2.1 Signal Wiring Diagrams : With ECOER Heat Pump

When the variable airflow is activated, Y2 is not required.

- Wiring for 4H2C thermostat(support auto airflow)

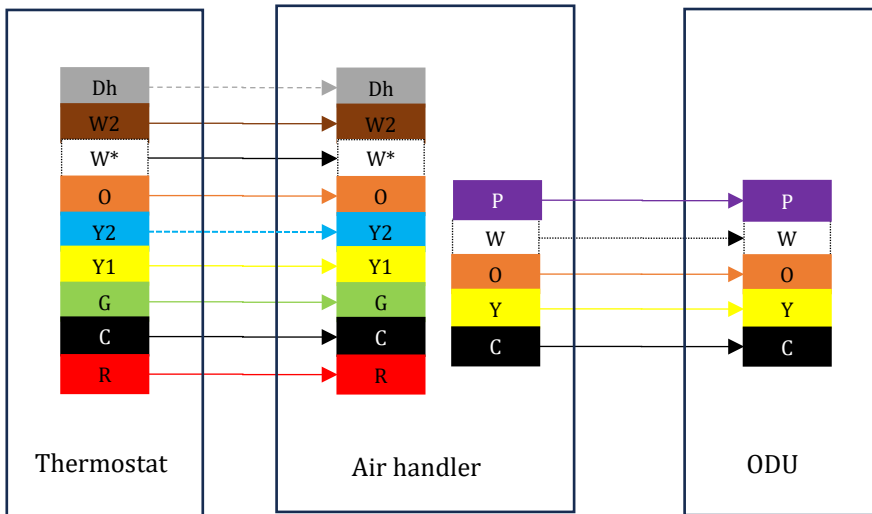

- Wiring for 2H1C thermostat (support auto airflow)

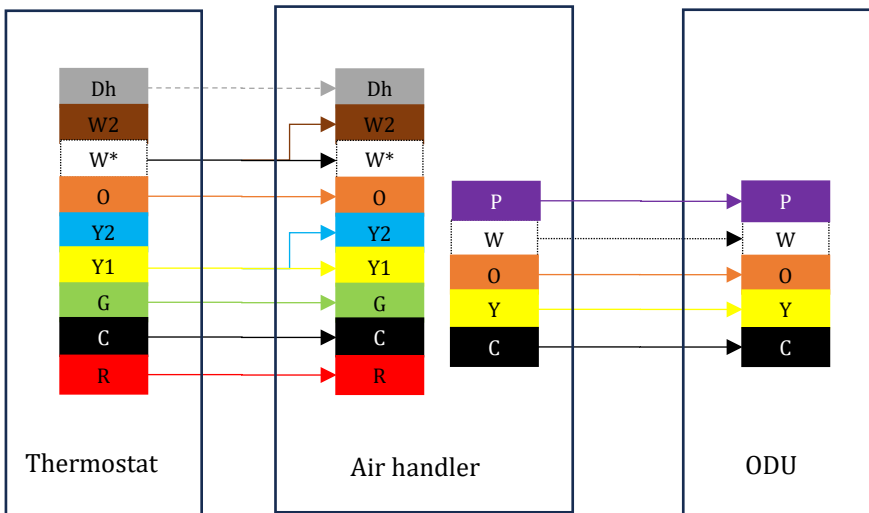

4.2.2 Signal Wiring Diagrams : With the third-party Heat Pump

- Wiring for 4H2C thermostat(setting 2-stage airflow)

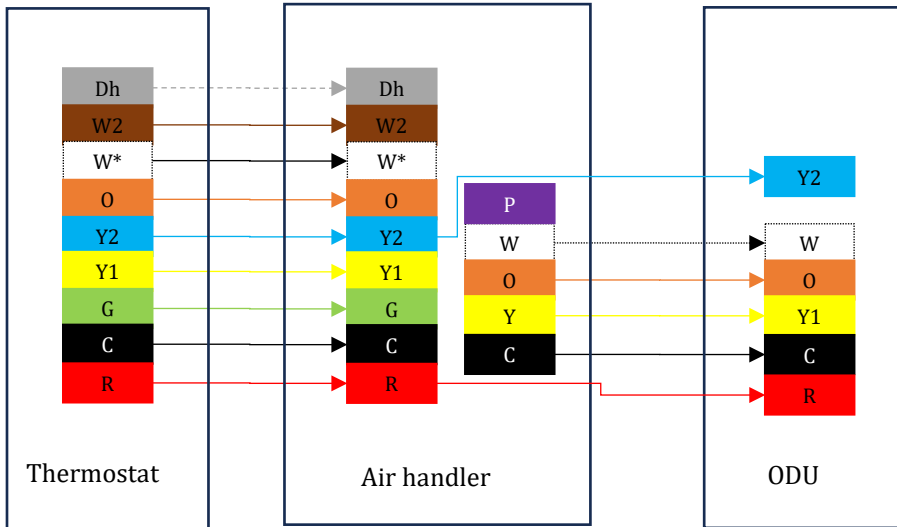

- Wiring for 2H1C thermostat (setting 2-stage airflow)

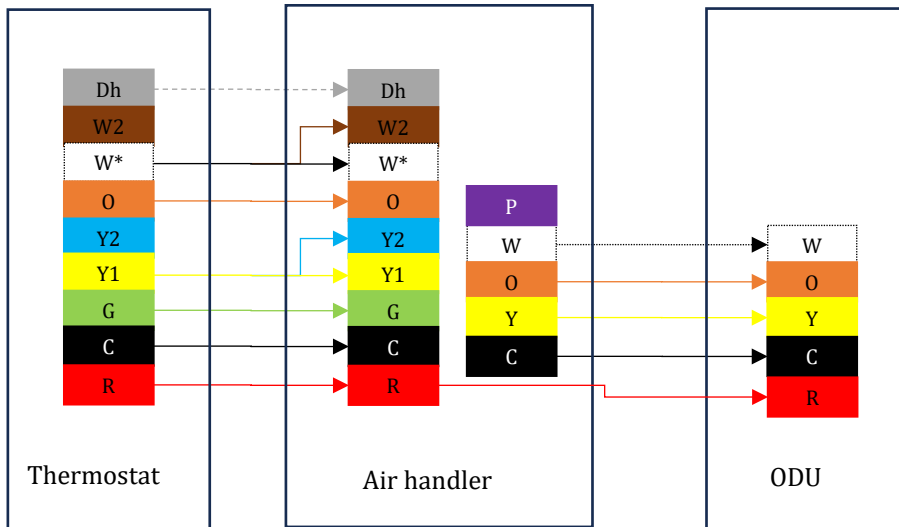

NOTICE

If the third-party ODU does not support capacity adjustment, select 2-stage air volume control by switch

4.2.3 Signal Wiring Diagrams : With the third-party cooling only

- Wiring for 4H2C thermostat(setting 2-stage airflow)

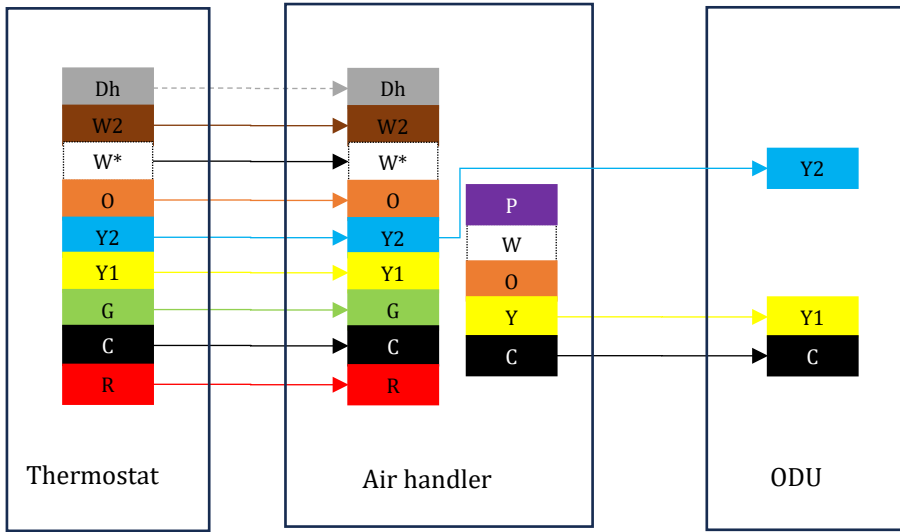

- Wiring for 2H1C thermostat (setting 2-stage airflow)

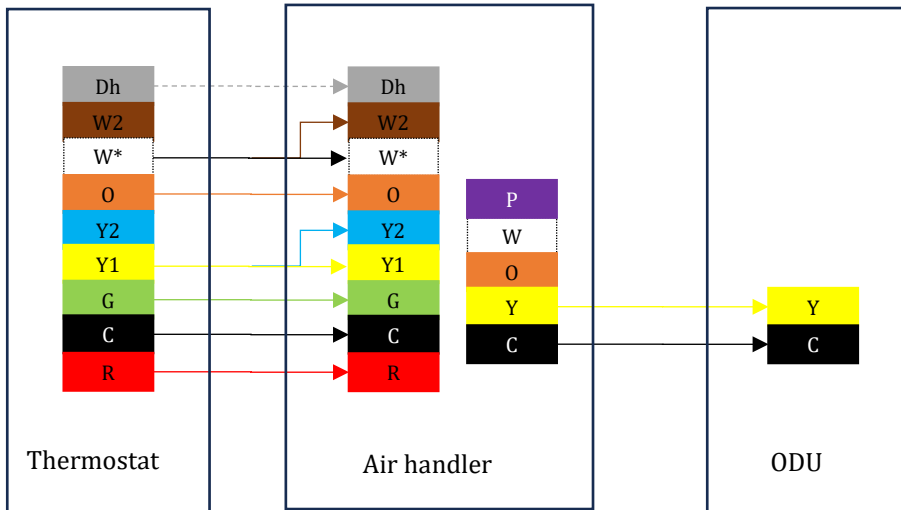

NOTICE

If the third-party ODU does not support capacity adjustment, select 2-stage air volume control by switch.

NOTES:

1. Be sure power supply agrees with equipment nameplate.
2. Power wiring and grounding of equipment must comply with local codes.
3. Low voltage wiring to be No. 18 AWG minimum conductor.
4. See the installation instructions and requirements of third-party devices on site.

4.3 Grounding

WARNING

The unit must be permanently grounded.

Failure to do so can result in electrical shock causing personal injury or death.

- Grounding may be accomplished by grounding metal conduit when installed in accordance with electrical codes to the unit cabinet. Grounding may also be accomplished by attaching ground wire(s) to ground lug(s) provided in the unit wiring compartment.
- Use of multiple supply circuits require grounding of each circuit to lug(s) provided in the unit.

4.4 Electrical Data

Model Number	Voltage-Phase-Hz	Power Supply Wiring Gauge	Motor HP	Minimum Circuit AMPS	Fuse (A)
24/36K	208/230V~1Ph~60Hz	14	1/2	5.4	15
	115V~1Ph~60Hz		1/2	8	15
48/60K	208/230V~1Ph~60Hz	14	1	9.8	15
	115V~1Ph~60Hz		1	14.4	20

4.5 Electric Heat Data

Heater Kit Model	Nominal Power	Power		HEATER AMPS		MIN.CIRCUIT AMPS		MAX. FUSE OR BREAKER (HACR) AMPS	
	240	230	208	230	208	230	208	230	208
EHK05B	5	4.6	3.8	20	18.1	25	23	30	25
EHK08B	7.5	6.9	5.6	30	27.1	38	34	40	35
EHK10B	10	9.2	7.5	40	36.2	50	46	60	50
EHK15B	10+5	9.3+4.6	7.5+3.8	40+20	36.2+18.1	50+25	46+23	46+30	50+25
EHK20B	10+10	9.2+9.2	7.5+7.5	40+40	36.2+36.2	50+50	46+46	60+60	50+50

Electric heat kits are suitable for air handler multiple position installation.

Safety Cautions All electric work must be performed by qualified personnel.

EHK series is designed and approved to be installed in the EAHATN series air handlers.

- Check the EHK label to confirm EHK size based on room load under lowest temperature ambient.
- Inspect all porcelain in insulators for breakage and the intact of heater element wire. Contact local distributor immediately if there is any occurred damage.

WARNING

•Disconnect all external power supplies before performing installation and servicing. Turn off accessory heater power switch if applicable. Failure to do so may cause serious injury.

•EHK must be properly grounded and use copper supply wires.

•Make sure to follow national electric code and local regulations.

•When installing it in an enclosed area such as a garage, heater elements should have a minimum clearance of 18" from the floor to insure the proper ventilation.

4.6 Electric Heat Installation Guide

STEP 1. Unfasten 4 screws to take away the blower access panel of the air handler.

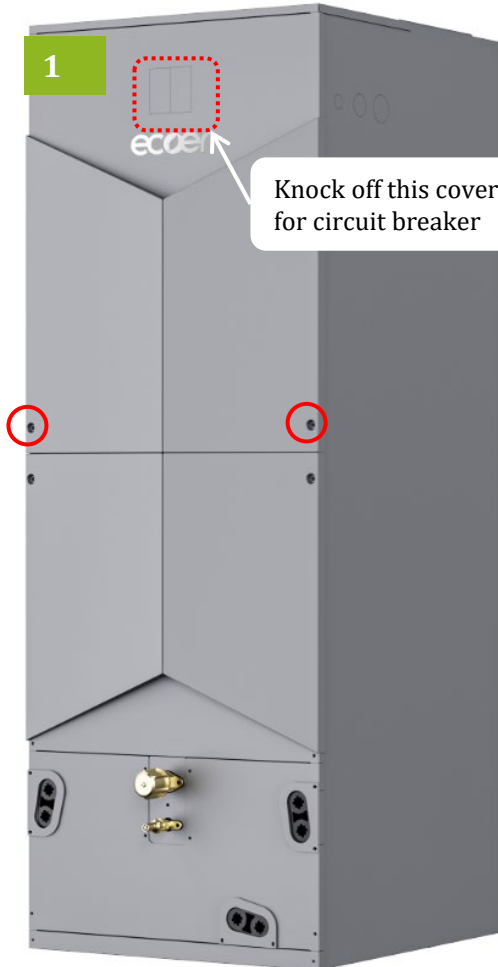

STEP 2. Remove cover plate based on actual requirement.



STEP 3. Slide the kit into the duct and fasten the element (e.g. attachment and wires).

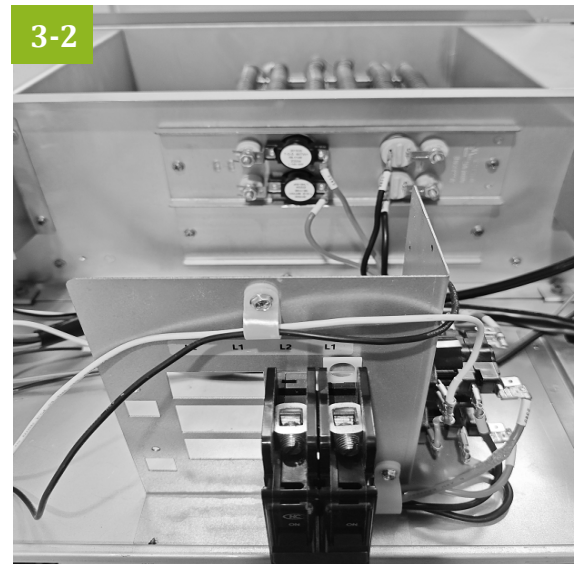
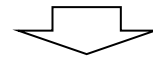

STEP 4. Install the circuit breaker into the mounting rail. Knock off the reserved cover for breaker in blower access panel prior to put it back to the unit.

4.6 Electric Heat Installation Guide

Electric Auxiliary Heat Installation Recommendations (24/36 K Btu models)

EHK05B / EHK08B / EHK10B Models:

It is recommended to install the electric heater module in the lower, position ① shown in the figure to enhance heat dissipation.

EHK15B Model:

It is recommended to install the 10 kW module in the position ① shown in the figure, and the 5 kW module in the position ②, to further optimize overall heat dissipation performance.

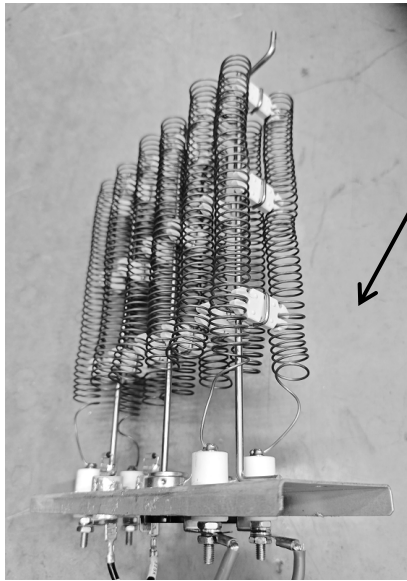

10 kW module of the 15 kW electric heater kit

Recommended Location (position ①) - 10 kW Electric Aux Heater Module

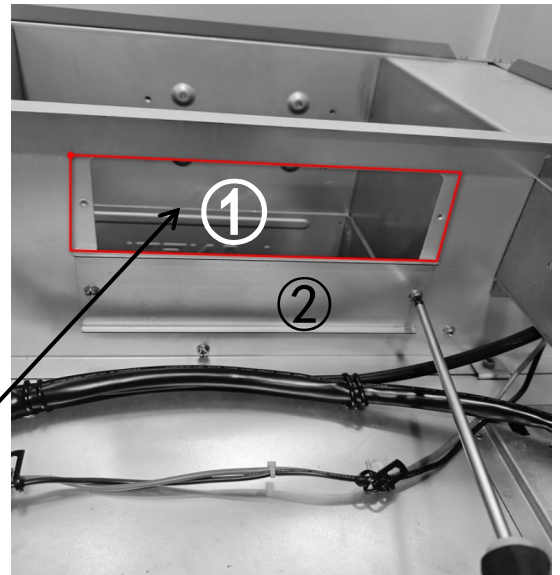

WARNING

Disconnect all power to unit before installing or servicing. More than one disconnect switch may be required to de-energize the equipment. Hazardous voltage can cause severe personal injury or death.

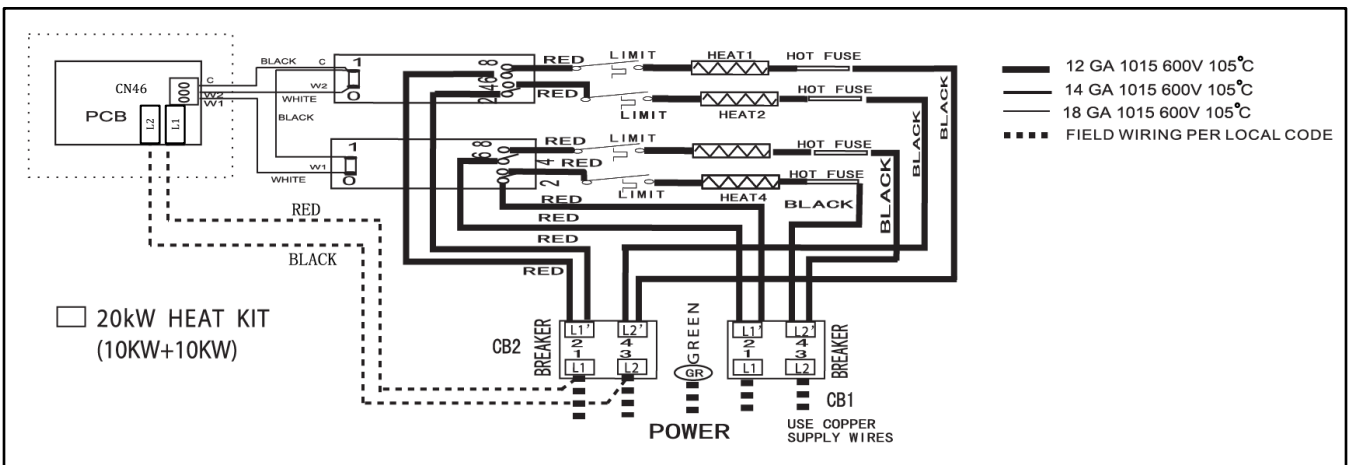
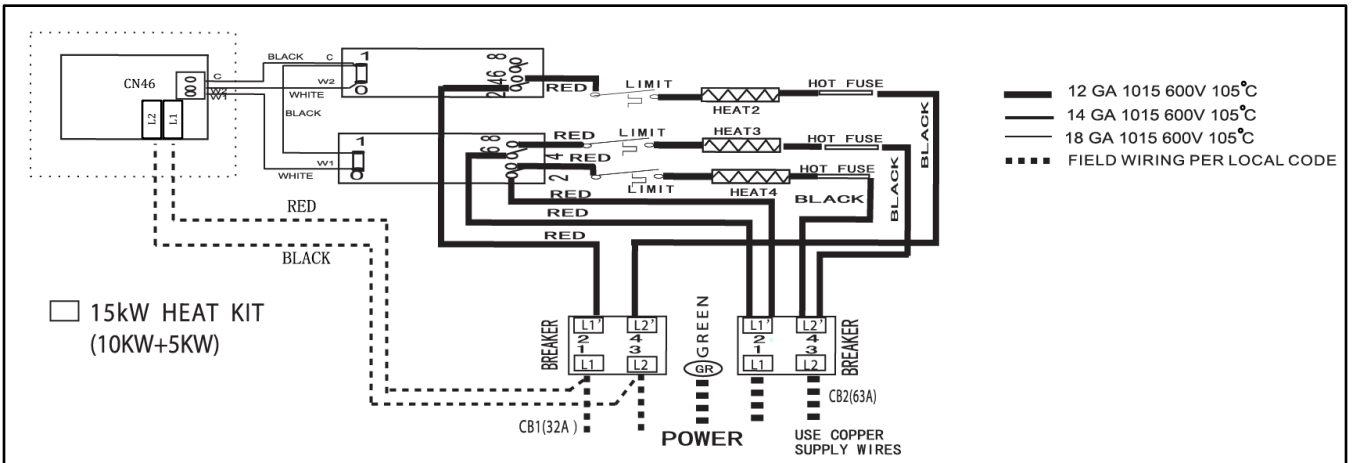
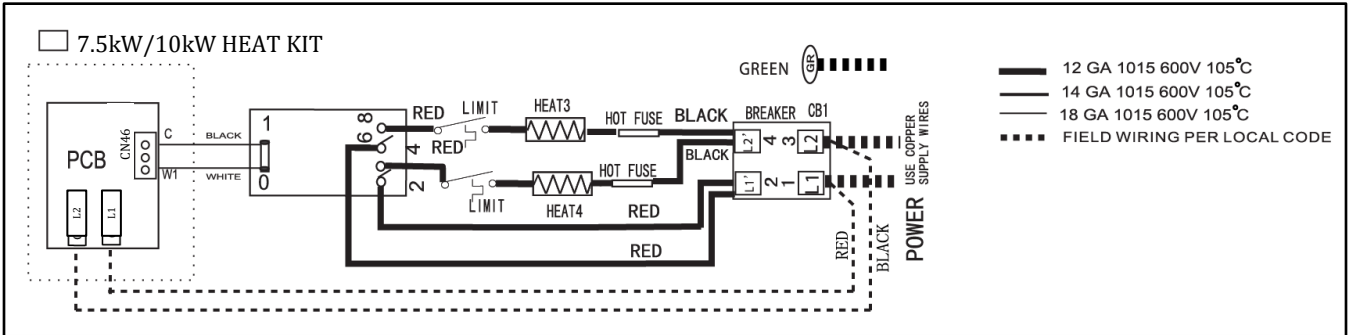
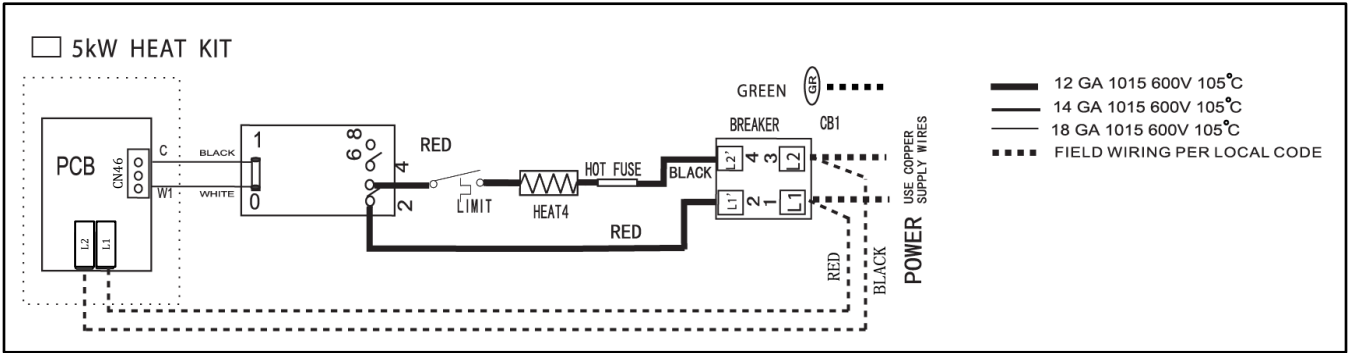

Figure 4-3 Wiring diagram for electric heat

5. Indoor Blower Control Function

NOTICE

When the switch is adjusted, it is necessary to power on again or press the reset button on PCB.

5.1 Airflow motor speed mode

Model	Airflow motor speed mode setting by SW1		Remark
	SW1-1	Airflow motor mode setting	
All	ON	2-stage airflow mode	/
	OFF	Variable airflow mode	Default

The unit supports the 2-stage fan control which requires a two stage thermostat (Y1/Y2) and the variable speed control by Y1.

5.2 Anti-cold airflow delay in heating

Model	Anti-cold airflow delay setting in heating by SW1		Remark
	SW1-2	Anti-cold airflow delay	
All	ON	Disable	/
	OFF	Enable	Default

Model	Type	Delay entry meets the conditions	Action	Remark
All	Enter	Heating start or heating operation & The coil temperature is lower than 87°F & W*=off	Fan motor delayed start, or running low speed when fan motor is on.	/
	Quit	Heating stops, or The coil temperature is more than 95°F, or W*=on	Return to normal fan speed	/

The unit supports the fan motor delay in heating according to the coil temperature. This function requires that the DIP switch of SW1-2 need be set to the OFF by default, it can be canceled by setting of SW1-2=ON.

5.3 Aux-E heater support

Model	Aux-E heater support setting by SW1		Remark
	SW1-3	Aux-E heater support setting	
All	ON	Disable	/
	OFF	Enable	Default

Aux-E heater support is enable by default, the fan motor will shut off in defrosting when it is disable.

5.4 O/B signal support

Model	O/B signal support setting by SW1		Remark
	SW1-4	Airflow motor speed setting	
All	ON	B signal enable	/
	OFF	O signal enable	Default

The unit supports the O/B signal setting by SW1.

5.5 Alarm input

Supports overflow switch alarm input to shut down the HVAC system. The CN3 terminal is in the normally closed state. If overflow switch needs to be connected, please replace the normally closed terminal wire with the connecting terminal wire with the connecting terminal wire in the accessory bag, and then connect the overflow switch. Note that the overflow switch should be a normally-closed type switch.

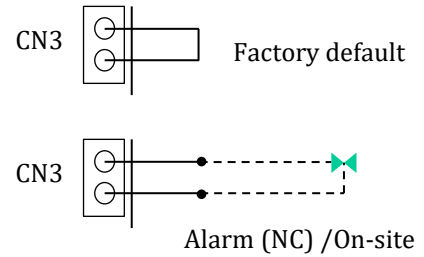

5.6 Refrigerant Leak Alarm output

An alarm output(CN1) can be utilized if actions are required when a fault is present. This is a passive outlet port, so you will need to input a voltage signal (24V). The relay is normally open for normal operation, and closed when a fault condition is active.

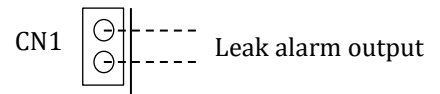

5.7 Refrigerant Leak Alarm Sound

When the R454B/R32 leaks or the leak sensor fails, the indoor unit is ventilated, the ODU stops running, and a continuous warning sound is emitted.



5.8 Dehumidifer support

When paired with the EST02 thermostat, the PCB supports control of the ventilator and dehumidifier.

This is a passive outlet port, so you will need to input voltage signal (24 V). The relay is normally open without demand and closed with demand.

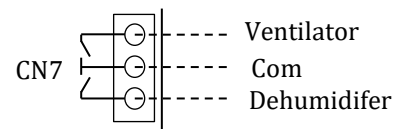

5.9 Humidifer support

When paired with the EST02 thermostat, the PCB supports control of the humidifier.

When humidification is required, the CN6 terminal will output a 24V signal.

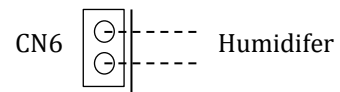

5.10 Configurable parameters

IMPORTANT

Note: Configuration parameter adjustments are only supported by the Ecoer Smart Service Pro App.

Symbol	Function	Item	Description
a01	Blower airflow setting	0	High airflow
		1 (factory)	Normal airflow
		2	Low airflow
a02	HVAC equipment AC/HP	0 (factory)	HP
		1	AC
a04	E-heater setting	0	No E-heater
		1	1-stage E-heater
		2(factory)	2-stage E-heater
a15	The static alarm limited*	1.20	inH20
a16	Max design static*	1.00	inH20
a18	RDS setting**	0	R454B
		1 (factory)	R454B
		2	R32
a19	Silent mode setting	0 (factory)	None silent mode
		1	Silent mode (level 1)
		2	Super silent mode (level 2)
		3	Night silent mode (level 1)
		4	Night super silent mode (level 2)
a20	Night silent setting- start time	0	17:00
		1 (factory)	18:00
		2	19:00
		3	20:00
		4	21:00
a21	Night silent setting- end time	0	5:00
		1 (factory)	6:00
		2	7:00
		3	8:00
		4	9:00

* Effective only when the air pressure sensor is installed.

** When the IDU communicates with the ODU, RDS automatically operates according to the ODU.

6. Airflow Performance

Airflow performance data is based on cooling performance with a coil and no filter in place. Check the Performance table for appropriate unit size selection. External static pressure should stay within the minimum and maximum limits shown in the table below in order to ensure proper airflow.

Airflow motor speed mode setting (SW1-1)					Variable airflow mode (Default)			2-stage airflow mode			
Model	Airflow setting	Airflow Dip-Switch			Max Airflow (CFM)	/ (CFM)	Min Airflow (CFM)	High Airflow (CFM)	Low Airflow (CFM)	Max available Static Pressure (in wc)	Remark
		SW2-1	SW2-2	SW2-3	W1/W2*	G*	/	Y2/W1/W2**	Y1/G**		
24K	Airflow 1	1	0	0	700	574	350	700	574	1.2	
	Airflow 2	1	0	1	760	623	350	760	623	1.2	
	Airflow 3	1	1	0	830	681	350	830	681	1.2	Default
	Airflow 4	1	1	1	880	722	350	880	722	1.2	
36K	Airflow 1	0	0	0	1050	735	350	1050	735	1.2	
	Airflow 2	0	0	1	1120	784	350	1120	784	1.2	
	Airflow 3	0	1	0	1200	840	360	1200	840	1.2	Default
	Airflow 4	0	1	1	1250	875	375	1250	875	1.2	
48K	Airflow 1	1	0	0	1450	1015	450	1450	1015	1.2	
	Airflow 2	1	0	1	1500	1050	450	1500	1050	1.2	
	Airflow 3	1	1	0	1550	1085	465	1550	1085	1.2	Default
	Airflow 4	1	1	1	1600	1120	480	1600	1120	1.2	
60K	Airflow 1	0	0	0	1650	1155	495	1650	1155	1.2	Default***
	Airflow 2	0	0	1	1700	1190	510	1700	1190	1.2	
	Airflow 3	0	1	0	1750	1225	525	1750	1225	1.2	
	Airflow 4	0	1	1	1800	1260	540	1800	1260	1.2	

* In Variable airflow mode, when the heat pump is operational, the airflow will adjust automatically. When the auxiliary heat (W1/W2) is activated, the system will run at maximum airflow. However, when only the blower is operating (G), the airflow will be fixed.

** In 2-stage airflow mode, the airflow will adjust according to the settings of the stages.

*** This is the max airflow when it is the downflow mode.

Notes: The airflow performance is based upon cooling performance at 230V with no electric heater and no filter. In 115V, 208V, 230V has the same airflow performance, because it has a constant airflow motor, which maintains its constant airflow output within the range of use, of course, when the maximum load of the motor may decline.

The air distribution system has the greatest effect on airflow. For this reason, the contractor should use only industry-recognized procedures to finish ductwork.

Heat pump systems require a specified airflow. Each ton of cooling requires between 300 and 450 cubic feet per minute (CFM). Duct design and construction should be carefully done. System performance can be lowered dramatically through bad planning or workmanship. Air supply diffusers must be selected and located carefully. They must be sized and positioned to deliver treated air along the perimeter of the space. Return air grilles must be properly sized to carry air back to the blower as well. Failure to follow these may cause abnormal noise and drafts.

The installers should balance the air distribution system to ensure proper quiet airflow to all rooms in the home. This ensures a comfortable living space.

7. Ductwork

Field ductwork must comply with the National Fire Protection Association NFPA 90A, NFPA 90B and any applicable local ordinance.

WARNING

Do not, under any circumstances, connect return ductwork to any other heat producing device such as fireplace insert, stove, etc. Unauthorized use of such devices may result in fire, carbon monoxide poisoning, explosion, personal injury or property damage.

Sheet metal ductwork run in unconditioned spaces must be insulated and covered with a vapor barrier. Fibrous ductwork may be used if constructed and installed in accordance with SMACNA Construction Standard on Fibrous Glass Ducts. Ductwork must comply with National Fire Protection Association as tested by U/L Standard 181 for Class I Air Ducts. Check local codes for requirements on ductwork and insulation.

- Duct system must be designed within the range of external static pressure the unit is designed to operate against. It is important that the system airflow be adequate. Make sure supply and return ductwork, grilles, special filters, accessories, etc. are accounted for in total flow resistance. Refer to the airflow performance table in this manual.
- Design the duct system in accordance with “ACCA” Manual “D” Design for Residential Winter and Summer Air Conditioning and Equipment Selection. Latest editions are available from: “ACCA” Air Conditioning Contractors of America, 1513 16th Street, N.W., Washington, D.C. 20036. If duct system incorporates flexible air duct, be sure that the pressure drop Information (straight length plus all turns) shown in “ACCA” Manual “D” is accounted for in system.
- Supply plenum is attached to the 3/4” duct flanges supplied with the unit. Attach flanges around the blower outlet.
- Secure the supply and return ductwork to the unit flanges, using proper fasteners for the type of duct used and tape the duct-to-unit joint as required to prevent air leaks.

IMPORTANT

If an elbow is included in the plenum close to the unit, it must not be smaller than the dimensions of the supply duct flange on the unit.

The front flange on the return duct connected to the blower casing must not be screwed into the area where the power wiring is located. Drills or sharp screw points can damage insulation on wires located inside unit.

8. Pipe Connections

8.1 Condensate Drain Connection

1. Use a thin layer of Teflon paste, silicone or Teflon tape when making drain fitting connections.
2. Do not over tighten fittings resulting in splitting pipe connections on the drain pan.

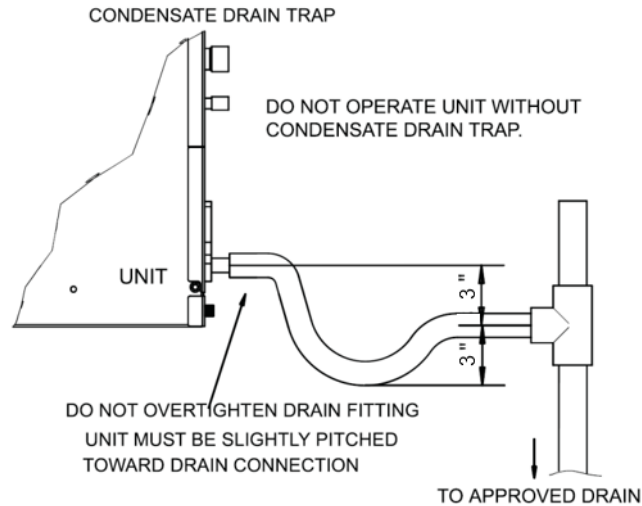

Figure 7-1 Condensate drain trap

- Make sure the drain pipes layout do not block service access. Minimum clearance of 24 inches is required for filter, coil or blower removal and service access.
- Ensure the unit is level or pitched slightly toward primary drain connection so that water will drain smoothly from the pan. All horizontal drain pipes must be pitched downward away from the unit a minimum of 1/8" per foot of line to ensure proper drainage.
- Do not reduce drain pipe size less than connection size provided on condensate drain pan.
- Do not connect condensate drain pipe to a closed or open sewer pipe.
- The drain pipe should be insulated where necessary to prevent sweating and damage due to condensate forming on the outside surface of the line.
- Make provisions for disconnecting and cleaning of the primary drain pipe if it become necessary. Install a 3-inch trap in the primary drain pipe as close as possible to the unit. Make sure that the top of the trap is below connection to the drain pan to allow complete drainage of pan.
- Auxiliary drain pipe should be connected to a place where it will be noticeable. Homeowner should be warned that a problem exists if water begins running from the auxiliary drain pipe.
- Test condensate drain pan and drain pipe after installation is complete. Pour enough water into drain pan, make sure that the drain pan is draining completely, no leaks are found in drain pipe fittings, and no water is draining from the termination of the primary drain pipe.

8.2 Refrigerant piping connection

WARNING

All field piping must be completed by a licensed technician and must comply with the local and national regulations.

- When the air conditioner is installed in a small room, measures must be taken to prevent the refrigerant concentration in the room from exceeding the safety limit in the event of refrigerant leakage. If the refrigerant leaks and its concentration exceeds its proper limit, hazards due to lack of oxygen may result.
- When installing the refrigeration system, ensure that air, dust, moisture or foreign substances do not enter the refrigerant circuit. Contamination in the system may cause poor operating capacity, high pressure in the refrigeration cycle, explosion or injury.
- Ventilate the area immediately if there is refrigerant leakage during the installation. Leaked refrigerant gas is both toxic and may be flammable. Ensure there is no refrigerant leakage after completing the installation work

Dimension specification of connecting pipe

Name	Model	Pipe specification		Remark
		Liquid Side	Gas Side	
Connecting pipe assembly	24K	Φ3/8in(Φ9.52mm)	Φ3/4in(Φ19mm)	Pipes are not included in the accessories and you need to purchase it separately from the local dealer
	36K	Φ3/8in(Φ9.52mm)	Φ3/4in(Φ19mm)	
	48K	Φ3/8in(Φ9.52mm)	Φ7/8in(Φ22mm)	
	60K	Φ3/8in(Φ9.52mm)	Φ7/8in(Φ22mm)	

Air-Handler Air Conditioners Refrigerant Piping Connection

The machine is equipped with two refrigerant connection pipes assemblies, which support both brazing and ZoomLock connection methods during installation.

Option 1: Refrigerant Line Brazing Connection

Remove the two plastic nuts on top of the machine to release the nitrogen stored inside the evaporator (see Figure 7-2).

Secure the refrigerant connection pipe assembly to the machine's pre-installed threaded joints using a threaded connection method. (Tightening torque is shown in Table) The copper pipes can rotate 360 degrees, and the brazing ends of the copper pipes can be adjusted to meet the installation requirements (see Figure 7-3).

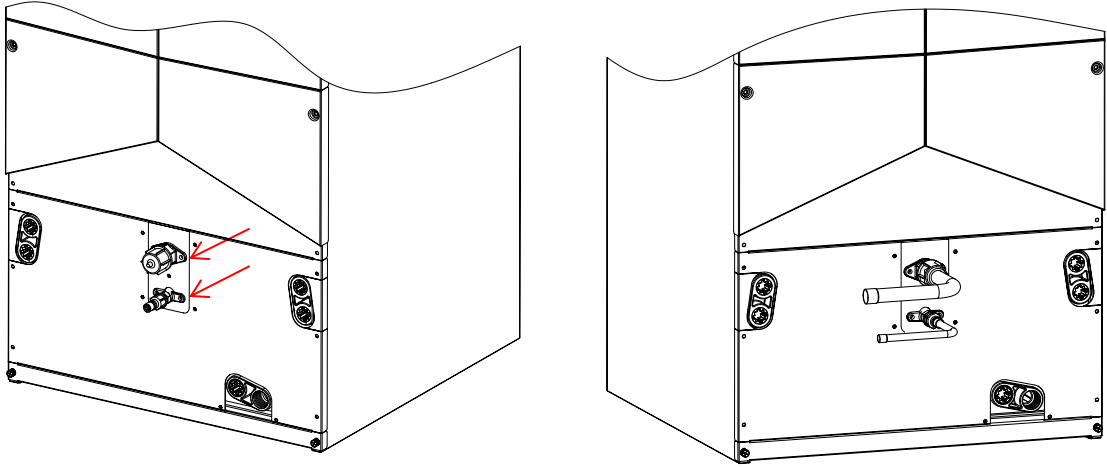

Figure 7-2

Tightening torque

Pipe gauge	Tightening torque
$\Phi 3/8\text{in}(\Phi 9.52\text{mm})$	32~39 N.m (320~390kgf.cm)
$\Phi 3/4\text{in}(\Phi 19\text{mm})$	67~87N.m (670~870kgf.cm)
$\Phi 7/8\text{in}(\Phi 22\text{mm})$	75~95N.m (750~950kgf.cm)

Option 2: Refrigerant Line Press Fitting Connection

This Press Fitting connection operation is for reference only. Please follow the official instructions provided by Press Fitting Tools for operation.

1. Use a rotary tube cutter to cut off the flaring structure of the copper tube.
2. Using a reamer or deburring tool, remove all burrs from the cut section of the pipe.
3. Use a pencil type deburrer on internal tube edges.
4. Thoroughly clean the tube end using a general purpose hand pad or sand cloth in a rotating motion.
5. Insert the tube fully into the fitting. Ensure tube is fully inserted prior to pressing
6. Align jaws squarely on the fitting, complete the joint with the approved tool. Press once only.

The Press Fitting connection has been completed.

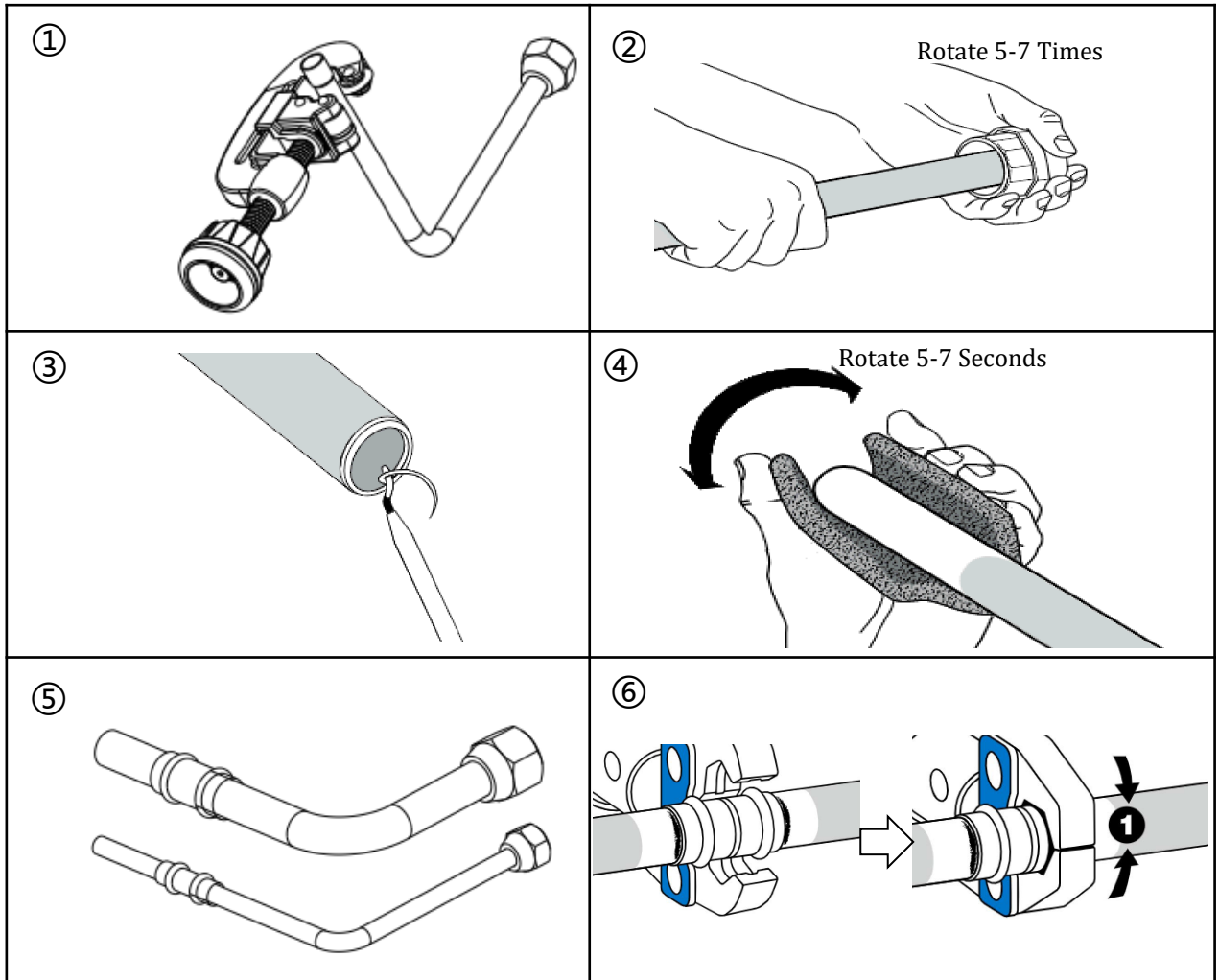

NOTICE

Do not deform pipe while cutting. Be extra careful not to damage, kink, or deform the pipe while cutting. This will drastically reduce the heating performance. The on-site operations should comply with the requirements of local standards.

9. Air Filter

Filter application and replacement are critical to airflow, which may affect the heating and cooling system performance. Reduced airflow can shorten the life of the system’s major components, such as motor, heat relays, evaporator coil or compressor. Units should be sized for a maximum of 300 feet/min. air velocity or what is recommended for the filter type installed.

Ensure the air flow is in the range of 300~450CFM if adding high efficiency filters or electronic air filtration systems. Note that the overall performance and efficiency of the unit will be reduced because of pressure drop by filters.

IMPORTANT

Do not double filter the return air duct.

Do not filter the supply air duct which will change the performance of the unit and reduce airflow .

WARNING

Do not operate the system without filters. A portion of the dust suspended in the air may temporarily lodge in the duct. Any circulated dust particles could be heated and charred by contact with the air handler elements. This residue could soil ceilings, walls, drapes, carpets and other articles in the house. Soot damage may occur without filters in place when certain types of candles, oil lamps or standing pilots are burned.

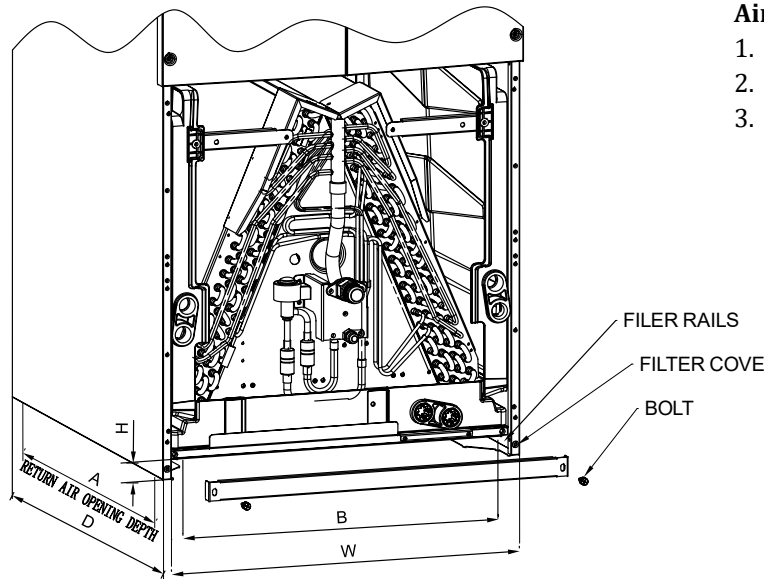

Air Filter Clean/Replacement

1. Remove bolts to take the filter cover away.
2. Hold the edge of the air filter and extract it out .
3. Clean the air filter or use a new one to replace.

NOTE: AIR FILTER IS NOT FACTORY INSTALLED.

Figure 8-1 Filter installation and clean

Model Number	Dimensions (in.)					
	Filter Size	W	D	H	A	B
24 / 36/48 / 60	18 x 20	19-3/4	21	1	16	13-7/8

NOTE:

1. Refer to the label on filter cover to install the correct filter size.

©2024 ECOER INC.

4040 McDermott Road, Suite 200
Plano, Texas 75024

Tel: 703-348-2538

www.ecoer.com