



## SUBMITTAL DATA SHEET

### One Way Cassette Heat Pump System

Location: _____ Engineer: _____ Submitted to: _____ Submitted by: _____ Reference: _____	Approval: _____ Date: _____ Construction: _____ Unit #: _____ Drawing #: _____
--	--

<b>Set Code</b>	22022510004788
Indoor unit code	22022511003936
Outdoor unit code	22022016015900
<b>Set Model</b>	
Indoor unit model	MIU-A18CO-2
Outdoor unit model	MOU-A18H-2
<b>Certified</b>	
AHRI	
UL	



### SYSTEM PERFORMANCE DATA

<b>Power supply</b>		
Normal Operational Voltage	(V, Ph, Hz)	208/230V, 1Ph, 60Hz
Voltage Range	(V)	187-253
<b>Electrical</b>		
Minimum circuit ampacity(Outdoor)	(A)	20.0
Max.fuse(Outdoor)	(A)	25.0
Connection wiring		14*4 AWG
<b>Cooling</b>		
Capacity	(Btu/h)	16700(6100~17500)
Power Input	(W)	1337(305~1880)
Current	(A)	8.30(2.2~8.0)
SEER2	(Btu/W)	19.8
EER2	(Btu/W)	12.5
<b>Heating</b>		
Capacity	(Btu/h)	20000(6450~21500)
Power Input	(W)	2086(1000~2220)
Current	(A)	12.3(4.5~9.5)
HSPF2-4	(Btu/W)	11.2
HSPF2-5	(Btu/W)	8.5
COP	W/W	2.81
Heat at 17F(H32)	(Btu/h)	14500
Heat at 5F(H42)	(Btu/h)	16700
COP at 5F(H42)	W/W	1.93

### REFRIGERANT PIPE DATA

Throttle type	Indoor unit	N/A
	Outdoor unit	EXV
Design pressure	(PSIG)	550/340
Refrigerant Type		R410A
Refrigerant charge	oz	65.26
Refrigerant precharge	(ft)	25.0
	(m)	7.5
Additional charge for each ft	(oz/ft)	0.16
Additional charge for each m	(g/m)	15.0
Liquid side/ Gas side(indoor)	(inch)	1/4" / 1/2"
	(mm)	6.35/12.7
Liquid side/ Gas side(outdoor)	(inch)	1/4" / 1/2"
	(mm)	6.35/12.7
Max. pipe length	(ft)	98.4
	(m)	30.0
Max. difference in level	(ft)	65.6
	(m)	20.0
Connection method		Flared
Indoor(cooling)	(Deg. °F)	60~90
	(Deg. °C)	16~32
Indoor(heating)	(Deg. °F)	32~86
	(Deg. °C)	0~30
Outdoor(cooling)	(Deg. °F)	-22~122
	(Deg. °C)	-30~50
Outdoor(heating)	(Deg. °F)	-22~75
	(Deg. °C)	-30~24

### INDOOR UNIT DATA

<b>Indoor fan motor</b>		
Model		ZKFN-30-8-43
Qty		1
Input	(W)	/
Output	(W)	30.0
RLA	(A)	1.50
Speed(Hi/Mi/Lo)	(r/min)	1344/1184/1024
<b>Air flow &amp; Noise level</b>		
Indoor air flow (Hi/Med/Lo) (No duct)	(CFM)	400.00/351.76/300.00/207.06
Indoor noise level (Hi/Med/Lo)	[dB(A)]	44/40.5/35
<b>Dehumidification</b>	(L/H)	2.18
<b>Indoor unit</b>		
Dimension (WxDxH)	(inch)	50.31x13.19x8.98
	(mm)	1278x335x228
Packing(WxDxH)	(inch)	57.60x22.48x22.64
	(mm)	1463x571x575
Net/Gross weight	(lbs.)	45.19/82.89
	(kg)	20.5/37.6

### OUTDOOR UNIT DATA

<b>Compressor</b>		
Type		Twin-ROTARY
Model		KTM240D43UKT
Brand		GMCC
Capacity	(Btu/h)	25931
Input	(W)	2045
Rated current (RLA)	(A)	14.3
Refrigerant oil/oil charge	(ml)	ESTER OIL VG74 620
<b>Outdoor fan motor</b>		
Model		ZKFN-80-8-3
Qty		1
Input	(W)	/
Output	(W)	80.00
RLA	(A)	0.76
Speed	(r/min)	810/720
<b>Air flow &amp; Noise level</b>		
Outdoor air flow (Max.)	(CFM)	1764.7
Outdoor noise level	[dB(A)]	57.5
<b>Outdoor unit</b>		
Dimension (WxDxH)	(inch)	35.04x13.46x26.50
	(mm)	890x342x673
Packing (WxDxH)	(inch)	39.17x15.67x29.13
	(mm)	995x398x740
Net/ Gross weight	(lbs.)	100.97/108.03
	(kg)	45.8/49

Indoor unit dimension

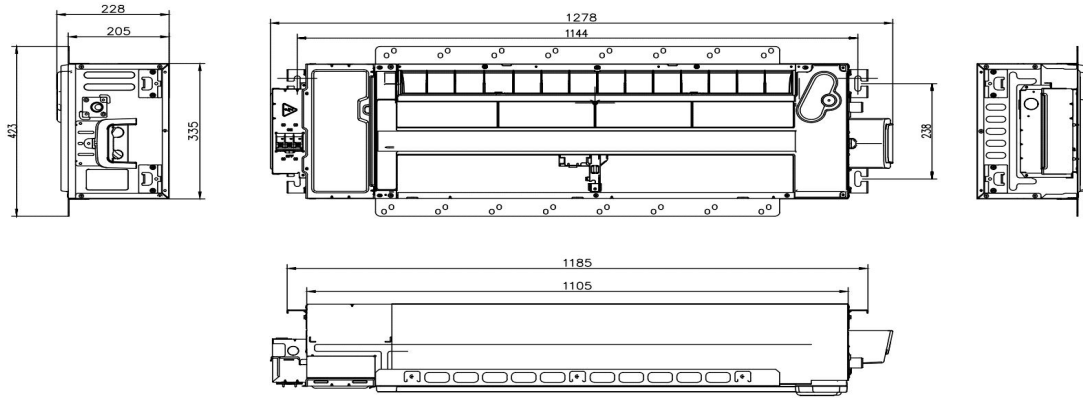

Outdoor unit dimension

