



Submittal Form

Project Name:	
Location:	
Engineer:	
Submitted to:	
Submitted by:	
Reference:	

Approval:	
Date:	
Construction:	
Unit #:	
Drawing #:	

MODEL #	
INDOOR:	MEHSU-48CSC2
OUTDOOR:	MCHSU-48CSH2



ELECTRICAL

Power supply	Ph-V-Hz	1-208/230-60
Minimum Circuit Ampacity	A	35
Maximum Fuse Size	A	50

COOLING

Capacity	Btu/h	48000(11600-49000)
Input	W	NA
Rated current	A	NA
EER	Btu/w	9.5
SEER	Btu/w	16.8

HEATING

Capacity	Btu/h	50000(11600-51000)
Input	W	NA
Rated current	A	NA
COP	A	3.1
HSPF	W/W	11
Low temperature heating capacity (5f)	Btu/h	16000

COMPRESSOR

Model		ATQ420DIUMU
Type		ROTARY
Brand		GMCC
Input	W	3420
Rated Current (RLA)	A	23.5
Refrigerant Oil/Charge	ml	Ester Oil VG74/1400

SYSTEM DATA

Design pressure	MPa	550/340 PSIG
Refrigerant	oz	R410A/148.2
Refrigerant precharge	ft	25
Additional charge per ft.	oz	0.161
Liquid	mm(in)	9.52(3/8")
Gas	mm(in)	15.9(5/8")
Max. refrigerant pipe length	ft.	213
Max difference in level	ft.	98

INDOOR UNIT DATA

Indoor fan		MEHSU-48CSC2
Model		ZKFN-170-8-1
Brand		WELLING
Input	W	170
RLA	A	10
Speed(Hi/Mi/Lo)	r/min	980/800/700
Indoor air flow (Hi/Mi/Lo)	CFM	1177/1030/853
Indoor noise level (Hi/Mi/Lo)	dB(A)	55/52/49

INDOOR UNIT DIMENSIONS

Dimension(WxDxH)	inch	33.07X33.07X11.3
Packaging (WxDxH)	inch	35.43X35.43X11.5
Net/Gross weight	lbs.	63.23/72.53

OUTDOOR UNIT DATA

Outdoor fan		MCHSU-48CSH2
Model		ZKFN-85-8-22
Brand		WELLING
Input	W	85
RLA	A	0.39
Speed	r/min	900
Outdoor air flow	CFM	4470
Outdoor noise level	dB(A)	62.5

OUTDOOR UNIT DIMENSIONS

Dimension(WxDxH)	inch	37.5X16.3X52.5
Packaging (WxDxH)	inch	43.11X19.49X58.27
Net/Gross weight	lbs.	217.4/246

OPERATION TEMPERATURE

Indoor(cooling/ heating)	Deg. F	62-90/32-86
Outdoor(cooling/heating)	Deg. F	5-122/5-86

ACCESSORIES

Wired Control	Model#	120G2
Installation Kit	Model#	Installation Kit 3
Piping Kit	Model#	PJX-3

Midea America Corp.

5 Sylvan Way, Parsippany, NJ 07054
P: (973) 539-5330 - F: (973) 539-5336
www.midea.com/us

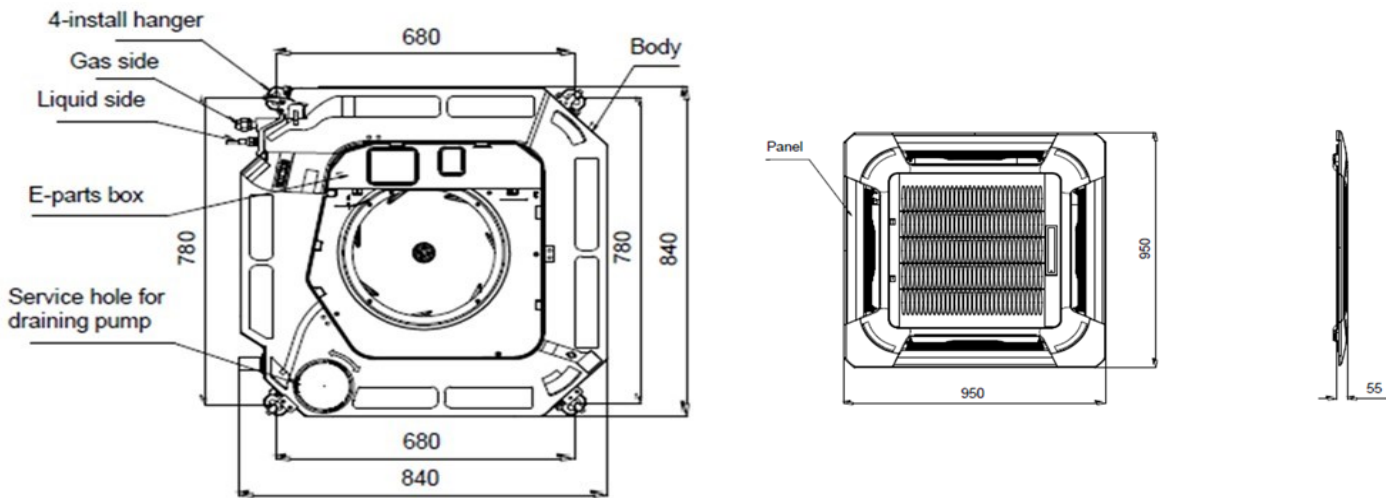

Dimensions	Width	Depth	Height
Inches	33 1/8	33 1/8	11 1/4

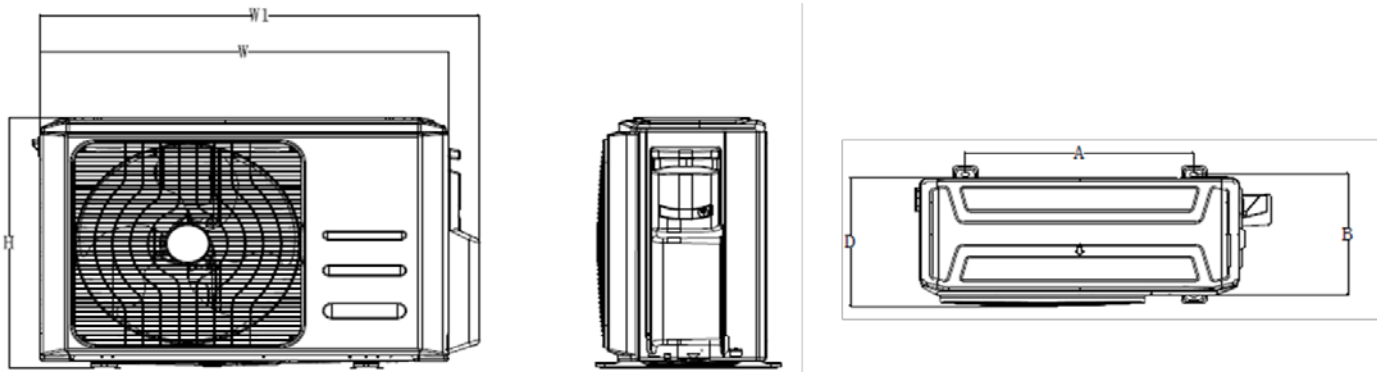

Dimensions	Width	Width 1	Depth	Height	A	B
Inches	37 1/2	41 1/8	16 1/4	52 1/2	25	15 7/8

Midea America Corp.

5 Sylvan Way, Parsippany, NJ 07054
 P: (973) 539-5330 - F: (973) 539-5336
www.midea.com/us