



Submittal Form

Project Name:	
Location:	
Engineer:	
Submitted to:	
Submitted by:	
Reference:	

Approval:	
Date:	
Construction:	
Unit #:	
Drawing #:	

MODEL #	
INDOOR:	MEHS-30PSH2
OUTDOOR:	MCHS-30PSH2



ELECTRICAL

Power supply	Ph-V-Hz	1-208/230-60
Minimum Circuit Ampacity	A	20
Maximum Fuse Size	A	30

COOLING

Capacity	Btu/h	30000(8000-30500)
Input	W	2400
Rated current	A	10.8
EER	Btu/w	12.5
SEER	Btu/w	20

HEATING

Capacity	Btu/h	30000(9000-34000)
Input	W	2500
Rated current	A	11
COP	A	N/A
HSPF	W/W	9.8
Low temperature heating capacity (5f)	Btu/h	16380

COMPRESSOR

Model		ATF250D22UMT
Type		ROTARY
Brand		GMCC
Input	W	2070
Related Current (RLA)	A	N/A
Refrigerant Oil/Charge	ml	Ester Oil VG74/670

SYSTEM DATA

Design pressure	MPa	550/340 PSIG
Refrigerant	oz	R410A/97
Refrigerant precharge	ft	25
Additional charge per ft.	oz	0.161
Liquid	mm(in)	6.35(3/8")
Gas	mm(in)	9.52(5/8")
Max. refrigerant pipe length	ft.	164
Max difference in level	ft.	82

INDOOR UNIT DATA

Indoor fan		MEHS-30PSH2
Model		ZKFP-58-8-1
Brand		WELLING
Input	W	58
RLA	A	N/A
Speed(Hi/Mi/Lo)	r/min	1180/900/700
Indoor air flow (Hi/Mi/Lo)	CFM	882/618/441
Indoor noise level (Hi/Mi/Lo)	dB(A)	51/44/33

INDOOR UNIT DIMENSIONS

Dimension(WxDxH)	inch	53.15X10.71X14.37
Packaging (WxDxH)	inch	58.07X14.76X18.11
Net/Gross weight	lbs.	43.2/55.6

OUTDOOR UNIT DATA

Outdoor fan		MCHS-30PSH2
Model		ZKFN-120-8-2
Brand		WELLING
Input	W	120
RLA	A	N/A
Speed	r/min	N/A
Outdoor air flow	CFM	2118
Outdoor noise level	dB(A)	60

OUTDOOR UNIT DIMENSIONS

Dimension(WxDxH)	inch	37.24X16.54X31.8
Packaging (WxDxH)	inch	42.91X19.69X34.06
Net Weight	lbs.	137.8

OPERATION TEMPERATURE

Indoor(cooling/ heating)	Deg. F	62-90/32-86
Outdoor(cooling/heating)	Deg. F	-13-122/-13-86

ACCESSORIES

Wired Control	Model #	120G1
Interface Kit	Model #	Interface Kit for 120G1
Installation Kit	Model #	Installation Kit 3

Midea America Corp.

5 Sylvan Way, Parsippany, NJ 07054
 P: (973) 539-5330 - F: (973) 539-5336
www.midea.com/us

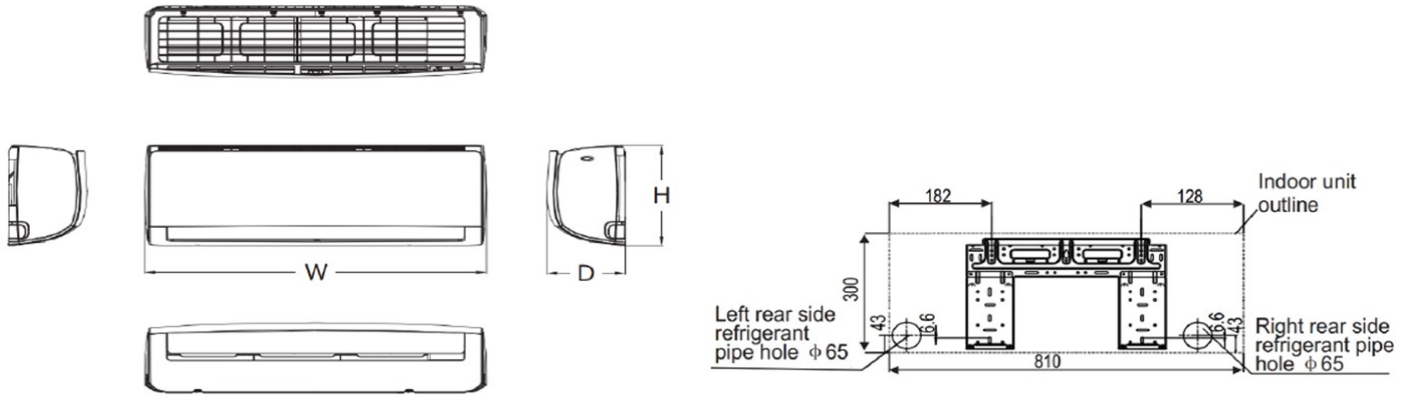

Dimensions	Width	Depth	Height
Inches	53 1/8	10 3/4	14 3/8

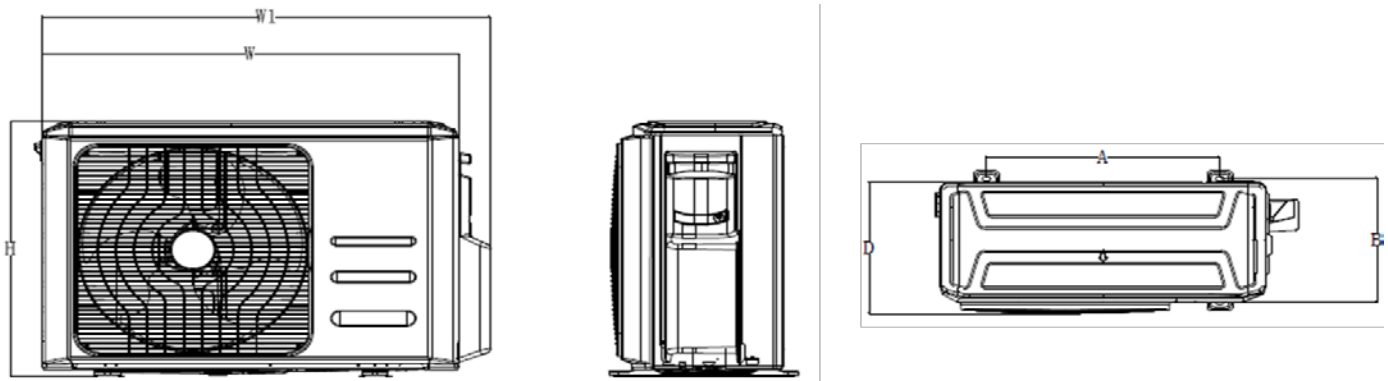

Dimensions	Width	Width 1	Depth	Height	A	B
Inches	37 1/4	40 5/8	16 1/2	31 6/8	26 1/2	15 7/8