



Submittal Form

MODEL

INDOOR:

MEHS-12NiH1

OUTDOOR:

MCHS-12NiH1



Project Name:	
Location:	
Engineer:	
Submitted to:	
Submitted by:	
Reference:	

Approval:	
Date:	
Construction:	
Unit #:	
Drawing #:	

ELECTRICAL

Power supply	Ph-V-Hz	115V, 60Hz, 1Ph
Minimum Circuit Ampacity	A	15
Maximum Fuse Size	A	25

COOLING

Capacity	Btu/h	9000 (2250-10000)
Input	W	
Rated current	A	8.9
EER	Btu/w	9
SEER	Btu/w	15

HEATING

Capacity	Btu/h	9000(2300-11000)
Input	W	
Rated current	A	7.9
COP	A	
HSPF 5°F	W/W	8.2
Low temperature heating capacity (-5°F)	Btu/h	5500

COMPRESSOR

Model		
Type		
Brand		
Input	W	
Related Current (RLA)	A	
Refrigerant	ml	Φ6.35/Φ9.52(1/4"/3/8")

SYSTEM DATA

Design pressure	MPa	
Refrigerant	oz	R410A
Refrigerant precharge	ft	
Additional charge per ft.	oz	31.8
Liquid	mm(in)	6.35 (1/4)
Gas	mm(in)	9.52 (3/8)
Max. refrigerant pipe length	ft.	82
Max difference in level	ft.	33

INDOOR UNIT DATA

Indoor fan motor		
Model		
Brand		
Input	W	
RLA	A	
Speed: Hi/Med/Lo	r/min	
Indoor air flow: Hi/Med/Lo	CFM	280/250/190
Indoor noise level: Hi/Med/Lo	dB(A)	39/35/29

INDOOR UNIT DIMENSIONS

Dimension(W*D*H)	inch	25.98*10.43*21.26
Packing (W*D*H)	inch	
Net weight	lbs.	15.43

OUTDOOR UNIT DATA

Outdoor fan motor		
Model		
Brand		
Input	W	
RLA	A	
Speed	r/min	
Outdoor air flow	CFM	
Outdoor noise level	dB(A)	

OUTDOOR UNIT DIMENSIONS

Dimension(W*D*H)	inch	26.77*7.01*10.04
Packing (W*D*H)	inch	
Net weight	lbs.	63.93

OPERATION TEMPERATURE

Cooling	Deg. F	32-122
Heating	Deg. F	5-86

ACCESSORIES



DIMENSIONS

MODEL: Neola Mini-Split 9000 BTU

INDOOR UNIT MODEL # MEHS-09NiH1

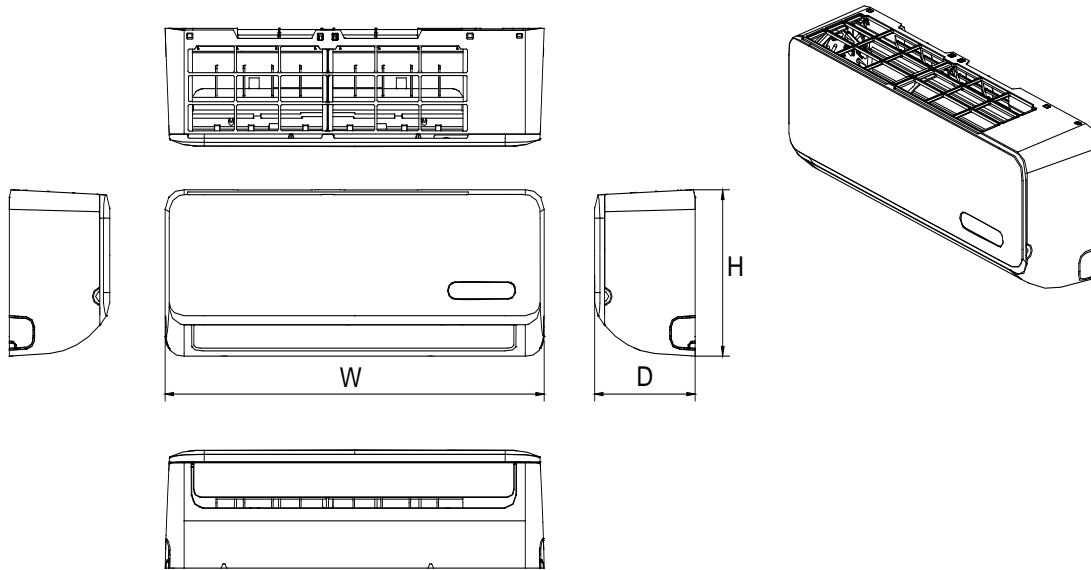

Model	W (inch)	H (inch)	D (inch)	Weight (lbs)
MEHS-09NiH1	25.98	21.26	10.43	15.43

OUTDOOR UNIT MODEL # MCHS-09NiH1

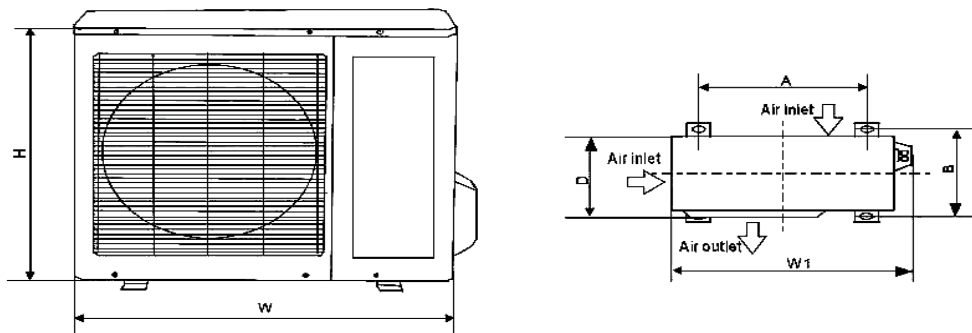

Model	W (inch)	H (inch)	D (inch)	Weight (lbs)
MCHS-09NiH1	26.77	10.04	7.01	63.93

Midea America Corp
 5 Sylvan Way
 Parsippany, NJ 07054

www.midea.com
 Tel: (973) 539-5330
 Fax: (973) 539-5336

