



Submittal Data Sheet

Project Name:			Approval:	
Location:			Date:	
Engineer:			Construction:	
Submitted to:			Unit #:	
Submitted by:			Drawing #:	
Reference:				

Code	2T0033100129
Factory model	US1-KFR88GW/BP2N1Y-CC12(P0)-W(IR)
Indoor code	220033101400
Indoor unit factory model	US1-KFR88G/BP2N1Y-CC12(P0)-W(IR)
Outdoor code	220038101310
Outdoor unit factory model	US1-KFR88W/BP2N1-310(P0)-W(IR)
Model	MEH-30LiH2
Indoor	MEH-30LiH2
Outdoor	MCH-30LiH2



PERFORMANCE DATA

Power supply	Ph-V-Hz	230V~ 60Hz, 1Ph
Cooling		
Capacity	Btu/h	30000
Input	W	2931
Rated current	A	13.1
EER	Btu/w	10
SEER	Btu/w	16
Heating		
Capacity	Btu/h	30000
Input	W	2442
Rated current	A	11
COP	W/W	3.6
HSPF4		9.6
HSPF5		/
Low temperature heating capacity (2°C)	Btu/h	/
Low temperature heating capacity (-7°C)	Btu/h	/
MINIMUM CIRCUIT AMPACITY	A	16.0
MAX.FUSE	A	25.0
Moisture Removal	L/h	3.2

Compressor Electrical

Model		DA250S2C-30MT
Type		Twin-rotary
Brand		GMCC
Capacity	Btu/h	26289
Input	W	2120
Rated current(RLA)	A	8.85
Locked rotor Amp(LRA)	A	----
Thermal protector		----
Thermal protector position		----
Refrigerant oil/oil charge	ml	ESTER OIL VG74/820
Connection wiring		16AWG*4
Plug type		/

INDOOR UNIT DATA

Indoor fan motor		
Model		YDK65-4B
Brand		Welling
Input		113/87/68
RLA	A	0.51
LRA	A	0.8
Winding Resistance	Ω	81/75.5
Capacitor	uF	3.0
Speed(Hi/Mi/Lo)	r/min	1260 / 1090 / 950
Air flow & Noise level		
Indoor air flow (Hi/Mi/Lo)	CFM	970/840/740
Indoor noise level (Hi/Mi/Lo)	dB(A)	50/47/43

Indoor unit

Dimension(W*D*H)	inch	56.89x10.91x13.39
Packing (W*D*H)	inch	60.24x16.54x14.37
Net/Gross weight	lbs.	52.91/70.55

OUTDOOR UNIT DATA

Outdoor fan motor		
Model		YDK53-6NB
Brand		Welling
Input		157.3/93.8
RLA	A	0.75
LRA	A	0.989
Winding Resistance	Ω	56.5/117.5
Capacitor	uF	2.5
Speed	r/min	790 / -- / 540
Air flow & Noise level		
Outdoor air flow	CFM	2060
Outdoor noise level	dB(A)	59

Outdoor unit

Dimension(W*D*H)	inch	35.43x12.40x33.86
Packing (W*D*H)	inch	41.06x15.55x36.02

Thermostat type		Remote Control
SYSTEM DATA		
Design pressure	MPa	550/340 PSIG
Refrigerant type	oz	R410A/89.94
Refrigerant precharge	ft	25
Additional charge per ft.	oz	0.322
Liquid side/ Gas side	mm(in)	Φ9.52/Φ15.9(3/8"/5/8")
Max. refrigerant pipe length	ft	164
Max. difference in level	ft.	82
Application area	sq.ft	473-789

Net/Gross weight	lbs.	156.53/165.35
Operation temperature		
Indoor(cooling/ heating)	Deg. F	62~90/32~86
Outdoor(cooling/heating)	Deg. F	32~122/5~86
Outdoor(cooling/heating)-optional	Deg. F	5~122/5~86

INDOOR UNIT

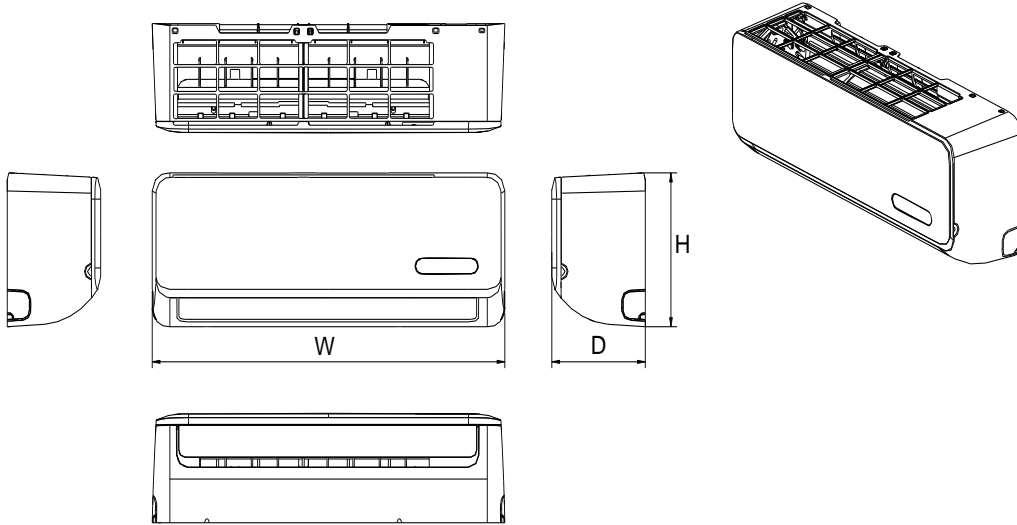

Model	W (inch)	H (inch)	D (inch)
MEH-30LiH2	56.89	10.91	13.39

OUTDOOR UNIT

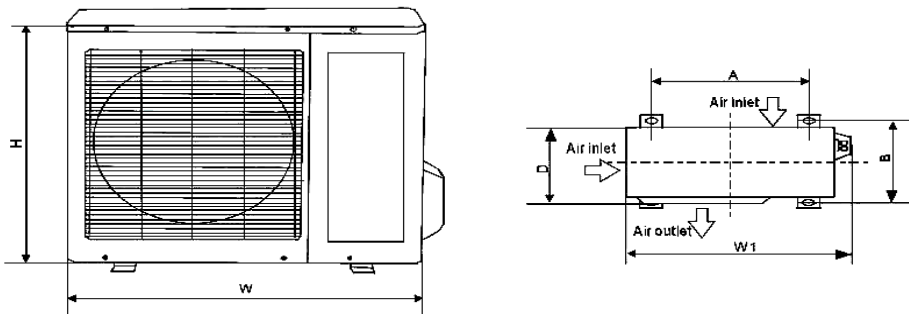

Model	W (inch)	H (inch)	D (inch)	W1 (inch)	A (inch)	B (inch)
MCH-30LiH2	35.43	12.40	33.86	38.58	23.23	13.11