



Submittal Data Sheet

Project Name:		Approval:	
Location:		Date:	
Engineer:		Construction:	
Submitted to:		Unit #:	
Submitted by:		Drawing #:	
Reference:			

Code	2T0032300805
Factory model	US1-KFR26GW/BP3N1Y-11M1(W0)-W
Indoor code	220032308590
Indoor unit factory model	US1-KFR26G/BP3N1Y-11M1(W0)-W
Outdoor code	220037306080
Outdoor unit factory model	US1-KFR26W/BP3N1-120(W0)-W
Model	MEHU-09AVH2
Indoor	MEHU-09AVH2
Outdoor	MCH-09AVH2



PERFORMANCE DATA

Power supply	Ph-V-Hz	208-230V~ 60Hz, 1Ph
Cooling		
Capacity	Btu/h	9000
Input	W	620
Rated current	A	2.695652174
EER	Btu/w	14.5
SEER	Btu/w	23.5
Heating		
Capacity	Btu/h	11500
Input	W	910
Rated current	A	3.956521739
COP	W/W	3.9
HSPF4		10
HSPF5		/
Low temperature heating capacity (2°C)	Btu/h	13201
Low temperature heating capacity (-7°C)	Btu/h	9898
MINIMUM CIRCUIT AMPACITY	A	9.0
MAX.FUSE	A	15.0
Moisture Removal	L/h	1.0

Compressor Electrical

Model		DA110S1C-30FZ
Type		Twin-rotary
Brand		GMCC
Capacity	Btu/h	11089
Input	W	850
Rated current(RLA)	A	4.45
Locked rotor Amp(LRA)	A	----
Thermal protector		1NT01L-4639 or KSD301
Thermal protector position		EXTERNAL
Refrigerant oil/oil charge	ml	ESTER OIL VG74/500
Connection wiring		16AWG*4
Plug type		/

INDOOR UNIT DATA

Indoor fan motor		
Model		WZDK20-38G
Brand		Shibaura
Input		20(Output)
RLA	A	0.09
LRA	A	/
Winding Resistance	Ω	/
Capacitor	uF	--
Speed(Hi/Mi/Lo)	r/min	1150 / 1000 / 700
Air flow & Noise level		
Indoor air flow (Hi/Mi/Lo)	CFM	440/380/260
Indoor noise level (Hi/Mi/Lo)	dB(A)	43/37/31

Indoor unit

Dimension(W*D*H)	inch	32.87x7.80x11.02
Packing (W*D*H)	inch	35.83x10.63x13.98
Net/Gross weight	lbs.	18.96/24.69

OUTDOOR UNIT DATA

Outdoor fan motor		
Model		WZDK35-38G(H)
Brand		Shibaura
Input		35(Output)
RLA	A	0.16
LRA	A	/
Winding Resistance	Ω	/
Capacitor	uF	--
Speed	r/min	800
Air flow & Noise level		
Outdoor air flow	CFM	1060
Outdoor noise level	dB(A)	54

Outdoor unit

Dimension(W*D*H)	inch	29.92x11.22x23.23
Packing (W*D*H)	inch	34.92x13.98x25.39

Thermostat type		Remote Control
SYSTEM DATA		
Design pressure	MPa	550/340 PSIG
Refrigerant type	oz	R410A/44.09
Refrigerant precharge	ft	25
Additional charge per ft.	oz	0.161
Liquid side/ Gas side	mm(in)	Φ6.35/Φ9.52(1/4"/3/8")
Max. refrigerant pipe length	ft	82
Max. difference in level	ft.	33
Application area	sq.ft	142-237

Net/Gross weight	lbs.	73.85/77.16
Operation temperature		
Indoor(cooling/ heating)	Deg. F	62~90/32~86
Outdoor(cooling/heating)	Deg. F	5~122/5~86
Outdoor(cooling/heating)-optional	Deg. F	/

INDOOR UNIT

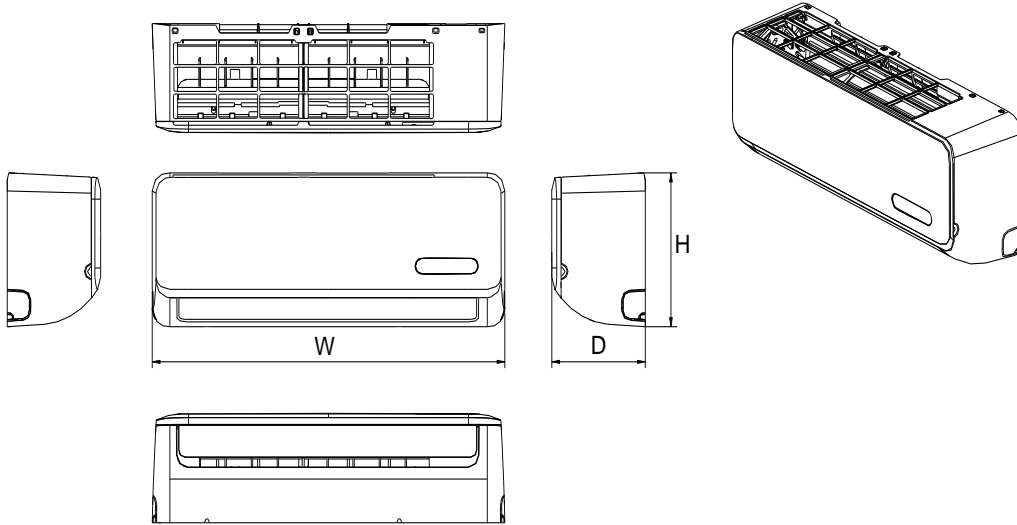

Model	W (inch)	H (inch)	D (inch)
MEHU-09AVH2	32.87	7.80	11.02

OUTDOOR UNIT

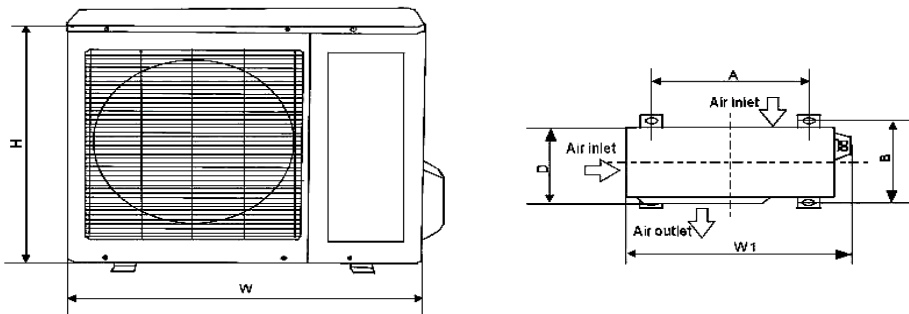

Model	W (inch)	H (inch)	D (inch)	W1 (inch)	A (inch)	B (inch)
MCH-09AVH2	29.92	11.22	23.23	32.40	20.87	11.42