



Submittal Data Sheet

Project Name:			Approval:	
Location:			Date:	
Engineer:			Construction:	
Submitted to:			Unit #:	
Submitted by:			Drawing #:	
Reference:				

Code	2T0032800584
Factory model	US1-KFR53GW/BP2N1Y-11D1(N10)-W
Indoor code	220032805570
Indoor unit factory model	US1-KFR53G/BP2N1Y-11D1(N10)-W
Outdoor code	220037804260
Outdoor unit factory model	US1-KFR53W/BP2N1-150(N10)-W
Model	MEH-18NiH2
Indoor	MEH-18NiH2
Outdoor	MCH-18NiH2



PERFORMANCE DATA

Power supply	Ph-V-Hz	208-230V~ 60Hz, 1Ph
Cooling		
Capacity	Btu/h	18000
Input	W	1920
Rated current	A	8.7
EER	Btu/w	9
SEER	Btu/w	15
Heating		
Capacity	Btu/h	18000
Input	W	1750
Rated current	A	8
COP	W/W	3
HSPF4		8.2
HSPF5		/
Low temperature heating capacity (2°C)	Btu/h	11000
Low temperature heating capacity (-7°C)	Btu/h	9901
MINIMUM CIRCUIT AMPACITY	A	14.0
MAX.FUSE	A	20.0
Moisture Removal	L/h	1.8

Compressor Electrical

Model		DA130M1C-31FZ
Type		ROTARY
Brand		GMCC
Capacity	Btu/h	13443
Input	W	1005
Rated current(RLA)	A	3.95
Locked rotor Amp(LRA)	A	----
Thermal protector		----
Thermal protector position		INTERNAL
Refrigerant oil/oil charge	ml	ESTER OIL VG74/480
Connection wiring		16AWG*4
Plug type		/

INDOOR UNIT DATA

Indoor fan motor		
Model		RPG28H
Brand		Welling
Input		58.5
RLA	A	0.3
LRA	A	0.356
Winding Resistance	Ω	183.6/206
Capacitor	uF	1.5
Speed(Hi/Mi/Lo)	r/min	1250 / 1100 / 800
Air flow & Noise level		
Indoor air flow (Hi/Mi/Lo)	CFM	440/390/280
Indoor noise level (Hi/Mi/Lo)	dB(A)	42/39/31

Indoor unit

Dimension(W*D*H)	inch	35.63x7.80x10.83
Packing (W*D*H)	inch	38.19x10.63x13.58
Net/Gross weight	lbs.	19.84/25.35

OUTDOOR UNIT DATA

Outdoor fan motor		
Model		YDK49-6B
Brand		Welling
Input		119/96
RLA	A	0.6
LRA	A	0.80
Winding Resistance	Ω	84.5/137
Capacitor	uF	2.5
Speed	r/min	860 / -- / 680
Air flow & Noise level		
Outdoor air flow	CFM	1350
Outdoor noise level	dB(A)	59

Outdoor unit

Dimension(W*D*H)	inch	29.92x11.22x23.23
Packing (W*D*H)	inch	34.92x13.98x25.39

Thermostat type		Remote Control
SYSTEM DATA		
Design pressure	MPa	550/340 PSIG
Refrigerant type	oz	R410A/42.3
Refrigerant precharge	ft	25
Additional charge per ft.	oz	0.161
Liquid side/ Gas side	mm(in)	Φ6.35/Φ12.7(1/4"/1/2")
Max. refrigerant pipe length	ft	98
Max. difference in level	ft.	66
Application area	sq.ft	284-473

Net/Gross weight	lbs.	82.67/88.18
Operation temperature		
Indoor(cooling/ heating)	Deg. F	62~90/32~86
Outdoor(cooling/heating)	Deg. F	32~122/5~86
Outdoor(cooling/heating)-optional	Deg. F	5~122/5~86

INDOOR UNIT

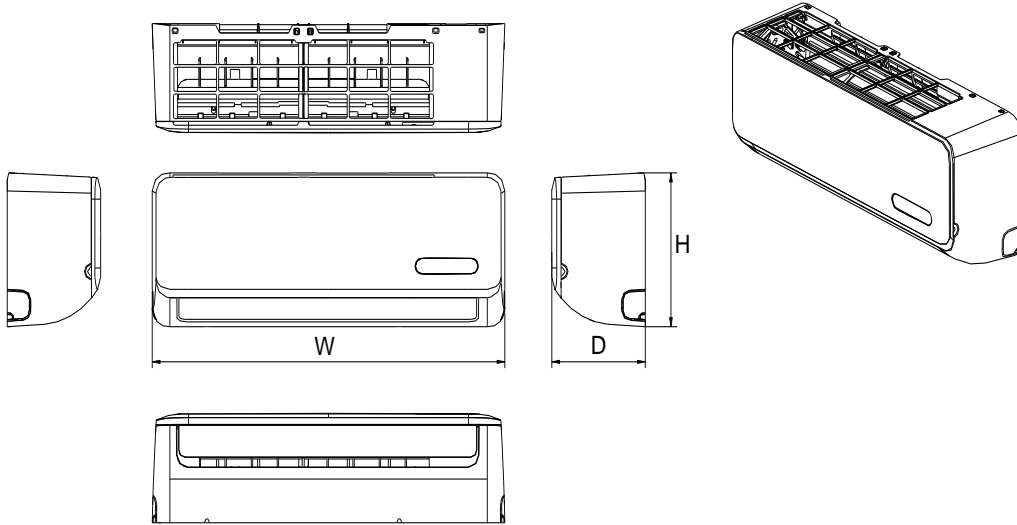

Model	W (inch)	H (inch)	D (inch)
MEH-18NiH2	35.63	7.80	10.83

OUTDOOR UNIT

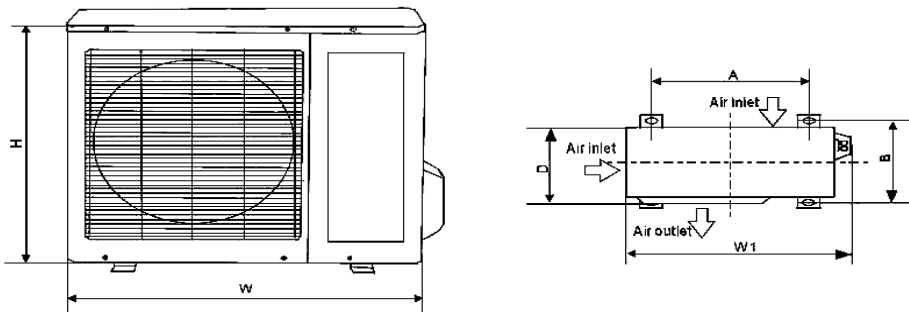

Model	W (inch)	H (inch)	D (inch)	W1 (inch)	A (inch)	B (inch)
MCH-18NiH2	29.92	11.22	23.23	32.40	20.87	11.42