

# DLCPRA

## INSTALLATION INSTRUCTIONS

### Outdoor Unit Single Zone Ductless System – Sizes 09 to 12



**NOTES:**

Read the entire instruction manual before starting the installation.  
Images are for illustration purposes only. Actual models may differ slightly.

#### TABLE OF CONTENTS

	PAGE
SAFETY CONSIDERATIONS .....	2
PARTS LIST .....	3
SYSTEM REQUIREMENTS .....	4
WIRING .....	4
DIMENSIONS – OUTDOOR .....	5
CLEARANCES – OUTDOOR .....	6
INSTALLATION TIPS .....	7
OUTDOOR UNIT INSTALLATION .....	7
ELECTRICAL DATA .....	9
CONNECTION DIAGRAM .....	9
SYSTEM VACUUM AND CHARGE .....	10
START-UP .....	11
OUTDOOR UNIT DIAGNOSTIC GUIDES .....	11

## SAFETY CONSIDERATIONS

Installing, starting up, and servicing air-conditioning equipment can be hazardous due to system pressures, electrical components, and equipment location (roofs, elevated structures, etc.).

Only trained, qualified installers and service mechanics should install, start-up, and service this equipment.

Untrained personnel can perform basic maintenance functions such as coil cleaning. All other operations should be performed by trained service personnel only.

When working on the equipment, observe the precautions in the literature and on tags, stickers, and labels attached to the equipment.

Follow all safety codes. Wear safety glasses and work gloves. Keep a quenching cloth and a fire extinguisher nearby when brazing. Use care in handling, rigging, and setting bulky equipment.

Read these instructions thoroughly and follow all warnings or cautions included in literature and attached to the unit. Consult local building codes and National Electrical Code (NEC) for special requirements. Recognize safety information.

This is the safety-alert symbol . When you see this symbol on the unit and in instructions or manuals, be alert to the potential for personal injury. Understand these signal words: **DANGER**, **WARNING**, and **CAUTION**. These words are used with the safety-alert symbol. **DANGER** identifies the most serious hazards which **will** result in severe personal injury or death. **WARNING** signifies hazards which **could** result in personal injury or death. **CAUTION** is used to identify unsafe practices which **may** result in minor personal injury or product and property damage.

**NOTE** is used to highlight suggestions which **will** result in enhanced installation, reliability, or operation.



## WARNING

### ELECTRICAL SHOCK HAZARD

Failure to follow this warning could result in personal injury or death.

Before installing, modifying, or servicing system, main electrical disconnect switch must be in the **OFF** position. There may be more than 1 disconnect switch. Lock out and tag switch with a suitable warning label.



## WARNING



### EXPLOSION HAZARD

Failure to follow this warning could result in death, serious personal injury, and/or property damage.

Never use air or gases containing oxygen for leak testing or operating refrigerant compressors. Pressurized mixtures of air or gases containing oxygen can lead to an explosion.



## CAUTION

### EQUIPMENT DAMAGE HAZARD

Failure to follow this caution may result in equipment damage or improper operation.

Do not bury more than 36 in. (914 mm) of refrigerant pipe in the ground. If any section of pipe is buried, there must be a 6 in. (152 mm) vertical rise to the valve connections on the outdoor units. If more than the recommended length is buried, refrigerant may migrate to the cooler buried section during extended periods of system shutdown. This causes refrigerant slugging and could possibly damage the compressor at start-up.

# PARTS LIST

**Table 1—Parts List**

PART NO.	PART NAME	QTY.
1	Outdoor unit	1
—	Literature package including installation instructions and warranty	1
—	Grommet to secure the outdoor unit (helps with vibration prevention during unit operation)	4
—	Drain Joint	1
—	Drain Hose	1

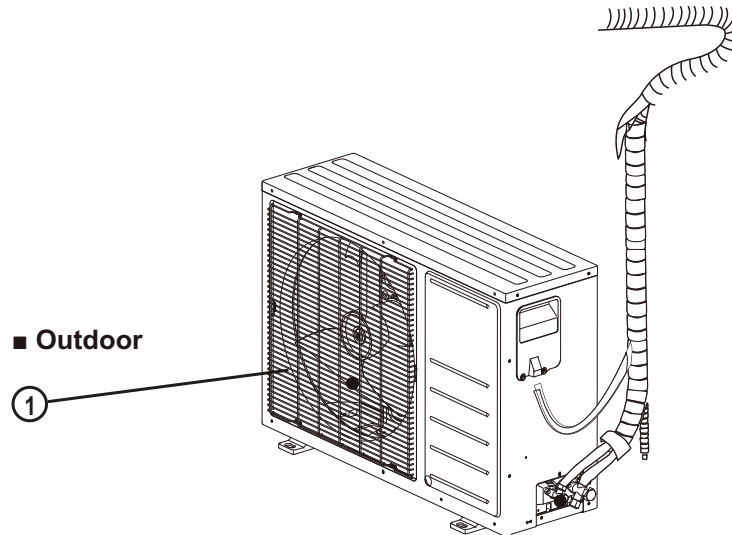

**Fig. 1 – Parts List**

A150766

**NOTE:**

- – If the outdoor unit is higher than the indoor unit, prevent rain from flowing into the indoor unit along the connection pipe by making a downward arc in the connection pipe before it enters the wall to the indoor unit. This ensures that rain drips from the connection pipe before it enters the wall.
- – Piping and the interconnecting wiring are field supplied.
- – The illustration above is only a sketch. Different models may be slightly different.

The following units are covered in these installation instructions.

**Table 2—Unit Sizes**

Heat Pump	SYSTEM TONS	BTUh	VOLTAGE – PHASE	OUTDOOR MODEL
	0.75	9,000	208/230–1	DLCBRAH09AAK
	1.00	12,000	208/230–1	DLCBRAH12AAK

## SYSTEM REQUIREMENTS

Allow sufficient space for airflow and service of the unit. See Fig. 3 for the required minimum distances between the unit, walls or ceilings.

### Piping

**IMPORTANT: Both refrigerant lines must be insulated separately.**

- Table 3 contains piping information for the product covered within this document.

**Table 3—Piping and Refrigerant Information**

System Size		9K (208–230V)	12K (208–230V)
<b>Piping</b>	Min. Piping Length	ft. (m)	10(3)
	Standard Piping Length	ft. (m)	25(7.5)
	Max. outdoor–indoor height difference (OU higher than IU)	ft. (m)	49(15)
	Max. outdoor–indoor height difference (IU higher than OU)	ft. (m)	49(15)
	Max. Piping Length with no additional refrigerant charge per System (Standard Piping length)	ft. (m)	25(7.5)
	Total Max. Piping Length per system	ft. (m)	98(30)
	Additional refrigerant charge (between Standard – Max piping length)	Oz/ft (g/m)	0.161(15)
	Suction Pipe (size – connection type)	In (mm)	3/8(9.52)
	Liquid Pipe (size – connection type)	In (mm)	1/4(6.35)
	Refrigerant Type	Type	R410A
<b>Refrigerant</b>	Heat Pump Models Charge Amount	Lbs (kg)	3.5 (1.6)

All outdoor units have an electronic expansion valve to manage the refrigerant flow of the fan coil connected.

## WIRING

All wires must be sized per NEC (National Electrical Code) or CEC (Canadian Electrical Code) and local codes. Use Electrical Data table MCA (minimum circuit amps) and MOCP (maximum over current protection) to correctly size the wires and the disconnect fuse or breakers respectively.

Per the caution note, only stranded copper conductors with a 600 volt insulation rating wire must be used.

### Recommended Connection Method for Power and Communication Wiring:

The main power is supplied to the outdoor unit. The field supplied 14/3 stranded wire with ground with a 600 volt insulation rating, power/communication wiring from the outdoor unit to indoor unit consists of four (4) wires and provides the power for the indoor unit. Two wires are line voltage AC power, one is communication wiring (S) and the other is a ground wire. Wiring between indoor and outdoor unit is polarity sensitive. The use of BX wire is NOT recommended.

If installed in a high Electromagnetic field (EMF) area and communication issues exists, a 14/2 stranded shielded wire can be used to replace L2 and (S) between outdoor unit and indoor unit landing the shield onto ground in the outdoor unit only.

## CAUTION

**EQUIPMENT DAMAGE HAZARD**

Failure to follow this caution may result in equipment damage or improper operation.

Wires should be sized based on NEC and local codes. Use copper conductors only with a 600 volt insulation rating wire.

## CAUTION

**EQUIPMENT DAMAGE HAZARD**

Failure to follow this caution may result in equipment damage or improper operation.

Be sure to comply with local codes while running wire from the indoor unit to the outdoor unit.

Every wire must be connected firmly. Loose wiring may cause the terminal to overheat or result in unit malfunction. A fire hazard may also exist. Ensure all wiring is tightly connected.

No wire should touch the refrigerant tubing, compressor or any moving parts.

Disconnecting means must be provided and shall be located within sight and readily accessible from the air conditioner.

Connecting cable with conduit shall be routed through the hole in the conduit panel.

# DIMENSIONS – OUTDOOR

Table 4—Dimensions and Weights

System Size		Height (H) in. (mm)	Width (W) in. (mm)	Depth (D) in. (mm)	Weight—Net lbs. (kg)
9K	(208/230V)	27.64(702)	33.27(845)	14.29(363)	107.59(48.8)
12K	(208/230V)	27.64(702)	33.27(845)	14.29(363)	108.47(49.2)

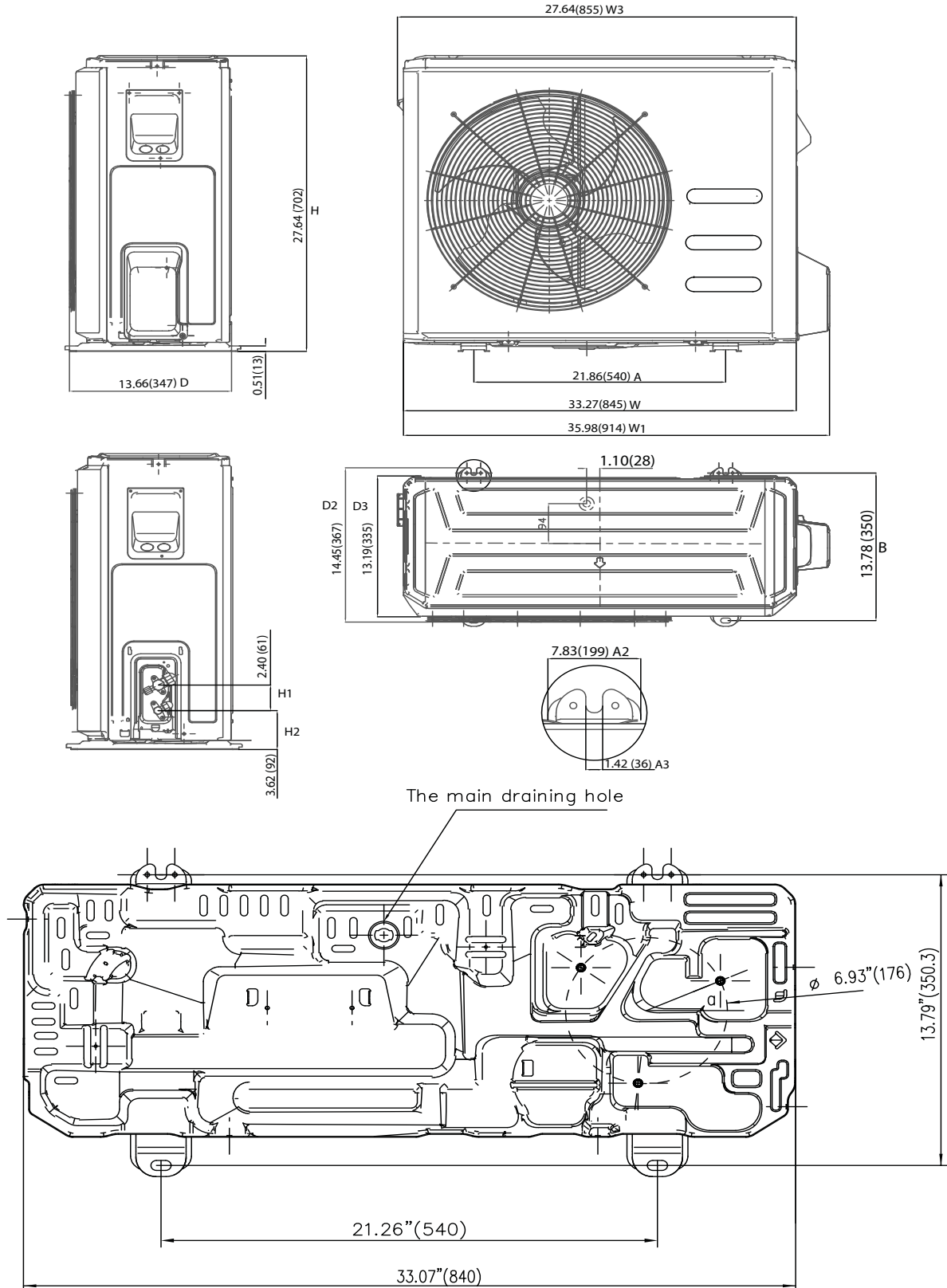
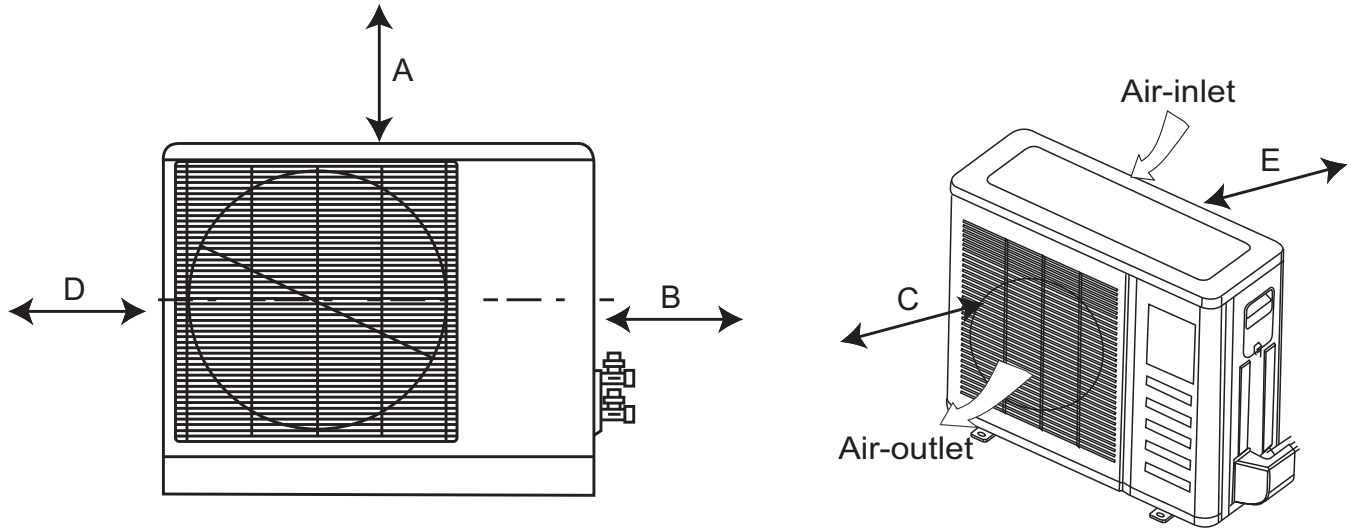

Fig. 2 – Sizes 9K and 12K

# CLEARANCES – OUTDOOR

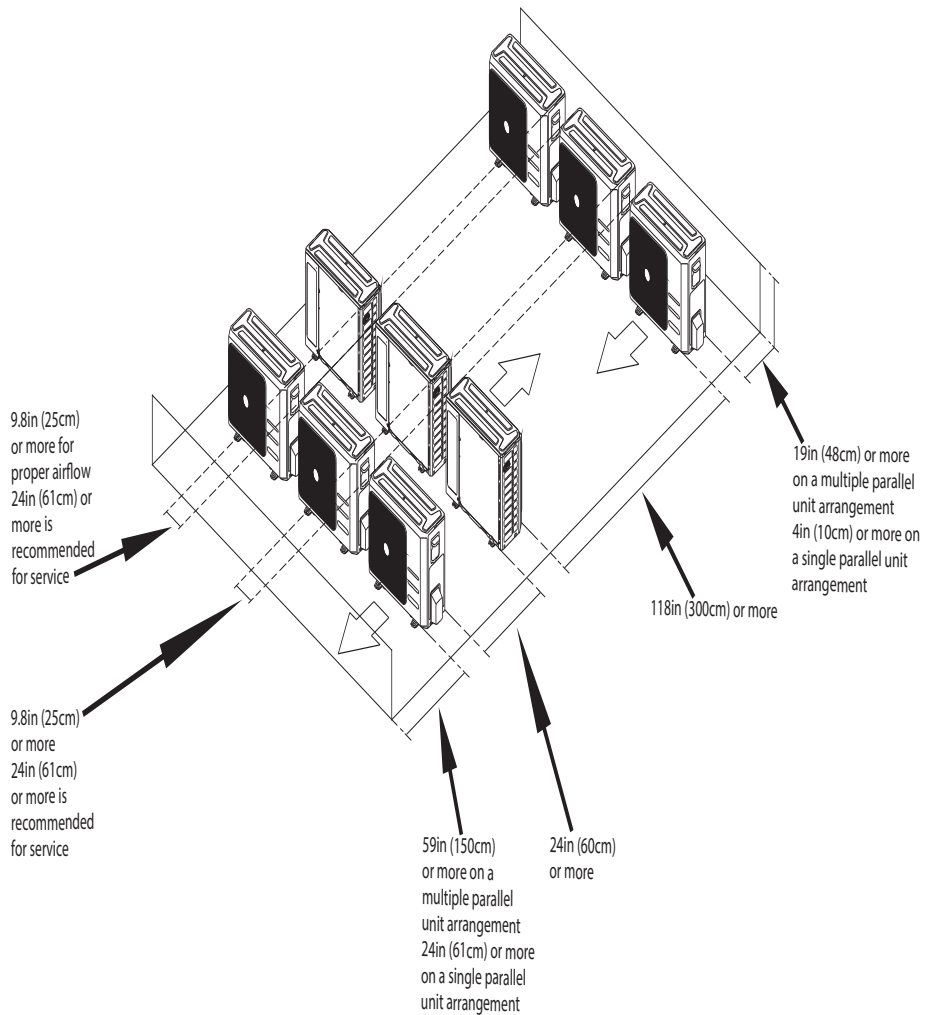

**Fig. 3 – Outdoor Unit Clearance**

**Table 5—Outdoor Unit Clearance Dimensions**

UNIT	MINIMUM VALUE in. (mm)
A	24 (610)
B	24 (610)
C	24 (610)
D	4 (101)
E	4 (101)

**NOTE:** The outdoor unit must be mounted at least 2in. (50mm) above the maximum anticipated snow depth.



**Fig. 4 – Clearances for multiple units**

## INSTALLATION TIPS

Ideal installation locations include:

### Outdoor Unit

- A location which is convenient to installation and not exposed to strong winds.
- A location which can bear the weight of the outdoor unit and where the outdoor unit can be mounted in a level position.
- A location which provides appropriate clearances (see Fig. 3).
- Do not install the indoor or outdoor units in a location with special environmental conditions. For those applications, contact your Ductless representative.

## OUTDOOR UNIT INSTALLATION

1. Use a rigid base to support the unit in a level position.
2. Locate the outdoor unit and connect piping and wiring.

⚠ **CAUTION**

**EQUIPMENT DAMAGE HAZARD**

Failure to follow this caution may result in equipment damage or improper operation.

In regions with snowfall and cold temperatures, avoid installing the outdoor unit in areas where it can be covered by snow. If the outdoor unit is installed in areas where heavy snow is expected, a field supplied ice or snow stand and/or field supplied—installed wind baffle should be installed to protect the unit from snow accumulation and/or blocked air intake. Blocking the air intake may result in reduced airflow, significantly reduced performance and damage to the equipment.

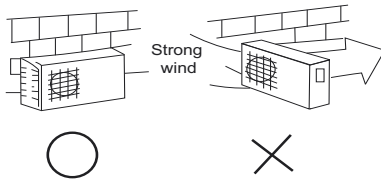

Fig. 5 – High Wind Installation

A07350

## MAKE REFRIGERANT PIPING CONNECTIONS (OUTDOOR UNIT)

**IMPORTANT: Use refrigeration grade tubing ONLY. No other type of tubing may be used. Use of other types of tubing will void the manufacturer's warranty.**

**Do not open the service valves or remove the protective caps from the tubing ends until all connections are made.**

Bend the tubing with bending tools to avoid kinks and flat spots.

Keep the tubing free of dirt, sand, moisture, and other contaminants to avoid damaging the refrigerant system.

Avoid sags in the suction line to prevent the formation of oil traps. Insulate each tube with a minimum 3/8-in. (10 mm) wall thermal pipe insulation. Inserting the tubing into the insulation before making the connections will save time and improve installation quality.

1. Remove the service valve cover, if provided with the unit.
2. Cut the pipe, with a pipe cutter, at 90 degrees (see Fig. 6).
3. Remove the service connection, if provided with the unit.

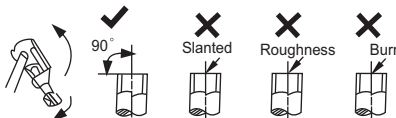

Fig. 6 – Cut the Pipe

4. Remove all the burrs from the cut cross section of the pipe avoiding any burrs inside the tubes.
5. Remove the flare nuts attached to the indoor and outdoor units.
6. Install the correct size flare nut onto the tubing and make a flare connection. Refer to Table 6 for the flare spacing dimensions.

Table 6—Flare Spacing

OUTER DIAM. (mm)	A (mm)	
	Max.	Min.
Ø1/4" (6.35)	0.05 (1.3)	0.03 (0.7)
Ø3/8" (9.52)	0.06 (1.6)	0.04 (1.0)
Ø1/2" (12.7)	0.07 (1.8)	0.04 (1.0)
Ø5/8" (15.88)	0.09 (2.2)	0.08 (2.0)

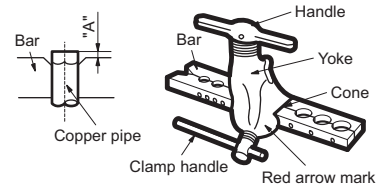

Fig. 7 – Flare Spacing

A150768

7. Apply a small amount of refrigerant oil to the flare connection on the tubing.
8. Align the center of the pipes and/or service valve.

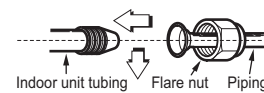

Fig. 8 – Align Pipe Center

A150769

9. Connect both the liquid and gas piping to the indoor unit.
10. Tighten the flare nut using a torque wrench as specified in Table 7.
11. Complete the installation.

Table 7—Tightening Torque

PIPE DIAMETER In. (mm)	TIGHTENING TORQUE	
	Ft-lb	N-m
Ø1/4" (6.35)	10 to 13	13.6 to 17.6
Ø3/8" (9.52)	24 to 31	32.5 to 42.0
Ø1/2" (12.7)	37 to 46	50.1 to 62.3
Ø5/8" (15.88)	50 to 60	67.7 to 81.3

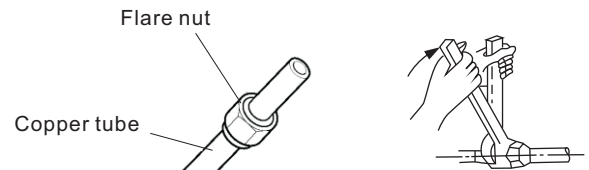

Fig. 9 – Tighten the Flare Nut

A150770

⚠ **CAUTION**

**EQUIPMENT DAMAGE HAZARD**

Failure to follow this caution may result in equipment damage or improper operation.

Excessive torque can break the flare nut depending on installation conditions.

## INSTALL ALL POWER AND INTERCONNECTING WIRING TO OUTDOOR UNITS

1. Mount the outdoor power disconnect.
2. Run the power wiring from the main box to disconnect per NEC and local codes.
3. Remove the field wiring cover from the unit by loosening the screws.
4. Remove the caps on the conduit panel.
5. Connect the conduit to conduit panel (see Fig. 10).
6. Properly connect both the power supply and control lines to the terminal block per the connection diagram for the appropriate unit capacity and voltage.
7. Ground the unit in accordance with NEC and local electrical codes.
8. Use the lock nuts to secure the conduit.
9. Reinstall the field wiring cover.



## CAUTION

### EQUIPMENT DAMAGE HAZARD

Failure to follow this caution may result in equipment damage or improper operation.

- Be sure to comply with local codes while running wire from indoor unit to outdoor unit.
- Every wire must be connected firmly. Loose wiring may cause the terminal to overheat or result in unit malfunction. A fire hazard may also exist. Therefore, ensure all wiring is tightly connected.
- No wire should be allowed to touch the refrigerant tubing, compressor or any moving parts.
- Disconnecting means must be provided and shall be located within sight and readily accessible from the air conditioner.
- Connecting cable with the conduit shall be routed through hole in the conduit panel.

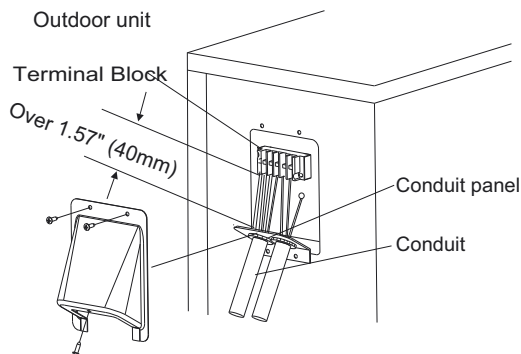

Fig. 10 – Field Wiring

A07455

## DRAIN CONNECTIONS

Install drains must meet local sanitation codes.

### Install the outdoor unit drain joint

Fit the seal into the drain joint, then insert the drain joint into the base pan hole of the outdoor unit. Rotate 90° to securely assemble them. Connect the drain joint with an extension drain hose to avoid condensate from draining off the outdoor unit during heating mode.

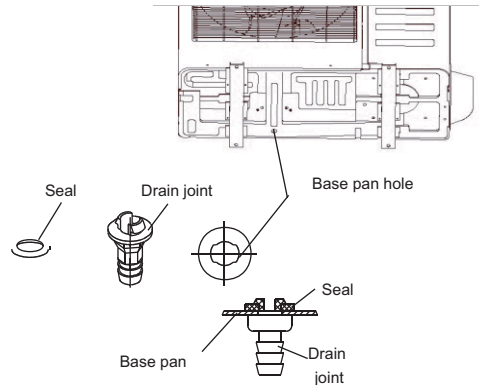

Fig. 11 – Drain Joint

Images are for illustration purposes only.



## CAUTION

In cold climates, ensure the drain hose is as vertical as possible to ensure swift water drainage.

If water drains too slowly, it can freeze in the hose and flood the unit.

**NOTE: Basepan built-in with multiple holes for proper draining during defrost. For applications where it is required to seal these holes, and re-direct the condensate drain, rubber plugs are available through RCD.**

Table 8—Base Pan Base Rubber Plugs

Outdoor Unit Model Number	Base Pan Base Rubber Plugs RCD Part Number	Quantity per unit
DLCBRAH09AAK	12600801A00077	25
DLCBRAH12AAK		



# ELECTRICAL DATA

**Table 9—Electrical Data (Heat Pump)**

Heat Pump	Outdoor Unit Size	9K	12K
	Volts—PH—Hz	(208/230V)	(208/230V)
	Max – Min* Oper. Voltage	253–187	253–187
Power Supply	MCA	13	15
	MOCP	15	20
Compressor	RLA	8.0	9.0
	FLA	0.6	0.6
Outdoor Fan Motor	Rated HP	0.156	0.156
	Output	50	50

\*Permissible limits of the voltage range at which the unit will operate satisfactorily.

**LEGEND**

- FLA – Full Load Amps
- MCA – Minimum Circuit Amps
- MOCP – Maximum Over-Current Protection
- RLA – Rated Load Amps

## CONNECTION DIAGRAM

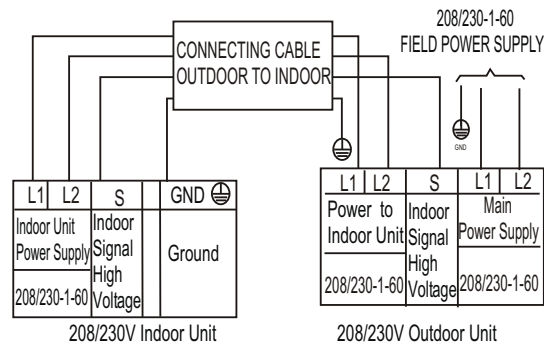

**Fig. 12 – Connection Diagram**

**Notes:**

1. Do not use the thermostat wire for any connection between indoor and outdoor units.
2. All connections between indoor and outdoor units must be as shown. **The connections are sensitive to polarity and will result in a fault code.**

## SYSTEM VACUUM AND CHARGE

### ⚠ CAUTION

#### UNIT DAMAGE HAZARD

Failure to follow this caution may result in equipment damage or improper operation.

Never use the system compressor as a vacuum pump.

Refrigerant tubes and the indoor coil should be evacuated using the recommended 500 microns deep vacuum method. The alternate triple evacuation method may be used if the procedure outlined below is followed.

**NOTE:** Always break a vacuum with dry nitrogen.

**NOTE:** Do not open the service valves until system evacuation is complete.

#### Using Vacuum Pump

1. Completely tighten flare nuts A, B, C, D, connect the manifold gage charge hose to a charge port of the low side service valve (see Fig. 13).
2. Connect the charge hose to vacuum pump.
3. Fully open the low side of manifold gage (see Fig. 14).
4. Start the vacuum pump.
5. Evacuate using either the deep vacuum or triple evacuation method.
6. After evacuation is complete, fully close the low side of manifold gage and stop the vacuum pump operation.
7. The factory charge contained in the outdoor unit is good for up to 25 ft. (8 m) of line length. For refrigerant lines longer than 25 ft. (8 m), add refrigerant, up to the allowable length, as specified in the System Requirements section.
8. Disconnect the charge hose from the charge connection of the low side service valve.
9. Fully open service valves B and A.
10. Securely tighten the service valve caps.

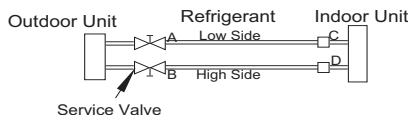

A07360

**Fig. 13 – Service Valve**

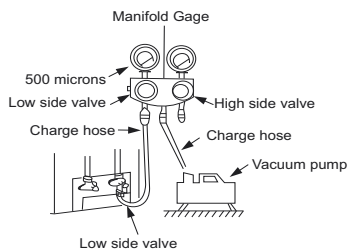

A07361

**Fig. 14 – Manifold**

#### Deep Vacuum Method

The deep vacuum method requires a vacuum pump capable of pulling a vacuum of 500 microns and a vacuum gage capable of accurately measuring this vacuum depth. The deep vacuum method is the best way to assure a system is free of air and liquid water (see Fig. 15).

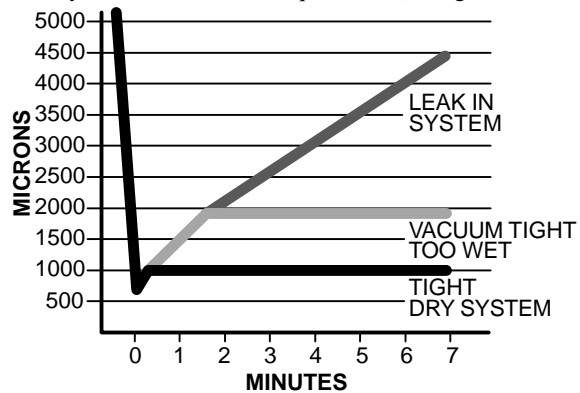

A95424

**Fig. 15 – Deep Vacuum Graph**

#### Triple Evacuation Method

The triple evacuation method should only be used when the vacuum pump is only capable of pumping down to 28 in. of mercury vacuum and the system does not contain any liquid water.

Refer to Fig. 16 and proceed as follows:

1. Pump the system down to 28 in. of mercury and allow the pump to continue operating for an additional 15 minutes.
2. Close the service valves and shut off the vacuum pump.
3. Connect a nitrogen cylinder and regulator to the system and open until the system pressure is 2 psig.
4. Close the service valve and allow the system to stand for 1 hr. During this time, dry nitrogen can diffuse throughout the system absorbing moisture.
5. Repeat this procedure as indicated in Fig. 16. The system will then be free of any contaminants and water vapor.

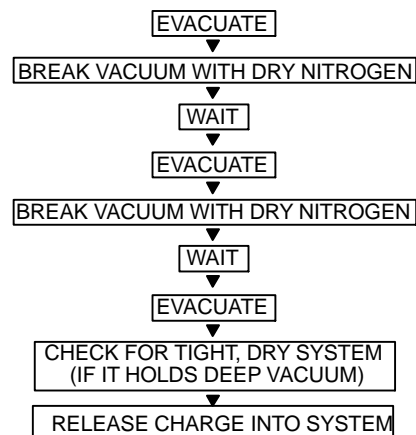

A95425

**Fig. 16 – Triple Evacuation Method**

#### Final Tubing Check

**IMPORTANT:** Check to be certain factory tubing on both the indoor and outdoor unit has not shifted during shipment. Ensure tubes are not rubbing against each other or any sheet metal. Pay close attention to the feeder tubes, and make sure the wire ties on the feeder tubes are secure and tight.

## START-UP

### Test Operation

Perform a test operation after completing a gas leak and electrical safety check. See the indoor unit installation instructions and owner's manual for additional start up information.

### SYSTEM CHECKS

1. Conceal the tubing where possible.
2. Make sure that the drain tube slopes downward along its entire length.
3. Ensure all tubing and connections are properly insulated.
4. Fasten the tubes to the outside wall, when possible.
5. Seal the hole through which the cables and tubing pass.

## OUTDOOR UNIT DIAGNOSTIC GUIDES

For ease of service, the systems are equipped with a diagnostic code display LEDs on both the indoor and outdoor units. The outdoor diagnostic is displayed on the outdoor unit microprocessor board.

There may be a few error codes displayed in the indoor unit that might relate to the outdoor unit's problems. If possible, always check the diagnostic codes displayed on the indoor unit first.

The diagnostic codes displayed on the outdoor units are listed on Table 10.

**Table 10—Unit Diagnostic Guides**

Display	LED STATUS
E0	Indoor unit EEPROM hardware error
E1	Indoor / outdoor units communication error
E2	Zero-crossing signal detection error
E3	Indoor fan speed has been out of control
E4	Indoor room temperature sensor T1 open circuit or short circuit
E5	Evaporator coil temperature sensor T2 open circuit or short circuit
EA	Indoor unit EEPROM parameter error
Eb	Communication error between the indoor PCB and display board
EC	Refrigerant leakage detection
EF	Intelligent eye module error
F1	Outdoor ambient temperature sensor T4 open circuit or short circuit
F2	Condenser coil temperature sensor T3 open circuit or short circuit
F3	Compressor discharge temperature sensor TP open circuit or short circuit
F4	Outdoor unit EEPROM parameter error
F5	Outdoor fan speed has been out of control
F6	Temperature sensor T2B (Located on the outdoor pipe) open circuit or short circuit
P0	IPM malfunction or IGBT over—strong current protection
P11/P10	Over voltage or over low voltage protection
P2	High temperature protection of IPM module
P4	Inverter compressor drive error
P6	Low pressure protection (Only for the outdoor unit with pressure switch)

For additional diagnostic information, refer to the Service Manual.

## OUTDOOR UNIT

Are there unusual noises or vibrations during operation?

**Explain the Following Items to the Customer (with the aid of the Owner's Manual):**

1. Explain care and maintenance.
2. Present the installation instructions to the customer.

